

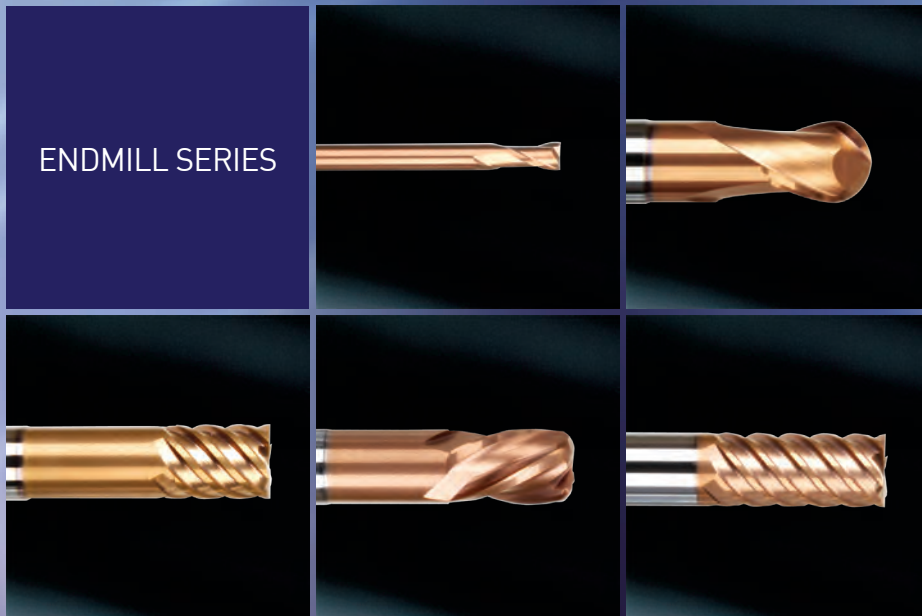













Zamus Star Series



Zamus Star Series



EDP. No.	APPEARANCE	FEATURE	STOCK	PAGE
ZSLNS20..... series		2 FLUTE, LONG NECK	•	37
ZSLNS40..... series		4 FLUTE, LONG NECK	•	42
ZSLNB..... series		2 FLUTE, LONG NECK	•	44
ZSLNR..... series		2 FLUTE, LONG NECK & BACK DRAFT TYPE	•	48
ZSTNB20..... series		2 FLUTE, TAPER NECK & BACK DRAFT TYPE		52
ZSTNB30..... series		3 FLUTE, TAPER NECK & BACK DRAFT TYPE		56
ZSTNR..... series		2 FLUTE, TAPER NECK & BACK DRAFT TYPE		57
ZS124 ...series		4 FLUTE, LONG CUT LENGTH BROKEN INDEX	•	59
ZS1(2)04 ...series		4 FLUTE, CORNER RADIUS BROKEN INDEX	•	60
ZS204series		4 FLUTE, CORNER RADIUS BROKEN INDEX	•	61
ZSPM4..... series		4 FLUTE, STUB CUT LENGTH, with EXTENDED NECK	•	63
DB702 ...series		2 FLUTE, STUB CUT LENGTH, BALL NOSE with EXTENDED NECK	•	64
DB712 ...series		2 FLUTE, REGULAR LENGTH, BALL NOSE	•	65
DB703 ...series		3 FLUTE, BALL NOSE for FINISHING MOLD & DIE	•	66
DB734 ...series		4 FLUTE, TAPER NECK for FINISHING MOLD & DIE	•	67

Zamus Star Series



EDP. No.	APPEARANCE	FEATURE	STOCK	PAGE
ZE702 ...series		2 FLUTE, STUB CUT LENGTH, with EXTENDED NECK	•	68
ZE704 ...series		4 FLUTE, STUB CUT LENGTH, with EXTENDED NECK	•	69
ZE724(6) ...series		4 & 6 FLUTE, FINISHING for MOLD & DIE	•	70
ZR702series		2 FLUTE, STUB CUT LENGTH, CORNER RADIUS with EXTENDED NECK	•	71
ZR732series		2 FLUTE, CORNER RADIUS with LONG SHANK	•	76
ZR704series		4 FLUTE, STUB CUT LENGTH, CORNER RADIUS with EXTENDED NECK	•	78
ZR714.....series		4 FLUTE, 45° HELIX FINISHING MOLD & DIE	•	81
ZR724series		4 FLUTE, STUB CUT LENGTH, CORNER RADIUS with LONG SHANK	•	82
ZR734series		4 FLUTE, CORNER RADIUS with LONG SHANK	•	83
ZR706series		6 FLUTE, 45° HELIX STUB CUT LENGTH, CORNER RADIUS with EXTENDED NECK	•	85
ZR736series		6 FLUTE, 45° HELIX, LONG SHANK, CORNER RADIUS	•	86
ZE712 ...series		2 FLUTE, 35° HELIX REGULAR LENGTH	•	87
ZE714 ...series		4 FLUTE, 45° HELIX REGULAR LENGTH	•	88
ZE716 ...series		6 FLUTE, 50° HELIX REGULAR LENGTH	•	89

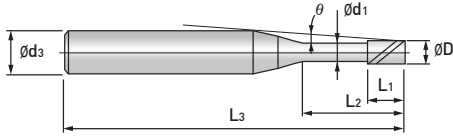

The effective neck length shown is not an exact value and to avoid contact with the workpiece, we recommend the user control the precise value of this length.

ZSLNS20....-.. series



EDP. No.	Dimension(mm)						Effective Neck Length					STOCK		
	D	L ₂	L ₁	d ₁	L ₃	d ₃	θ	0.5°	1°	1.5°	2°		3°	
ZSLNS2001-0.3	0.1	0.3	0.15	0.08	45	4	11.6	0.4	0.4	0.5	0.5	0.5	•	
ZSLNS2001-0.5		0.5						0.6	0.7	0.7	0.7	0.8	•	
ZSLNS2001-1		1						1.2	1.2	1.2	1.3	1.4	•	
ZSLNS2002-0.5	0.2	0.5	0.3	0.17	50	4	11.3	1.2	1.3	1.5	1.7	2.0	•	
ZSLNS2002-1		1						1.7	1.9	2.2	2.4	2.7	•	
ZSLNS2002-1.5		1.5						2.3	2.5	2.8	3.0	3.4	•	
ZSLNS2003-1	0.3	1	0.45	0.27	50	4	10.8	1.7	1.9	2.2	2.4	2.7	•	
ZSLNS2003-1.5		1.5						2.3	2.5	2.8	3.0	3.4	•	
ZSLNS2003-2		2						2.8	3.1	3.4	3.6	4.1	•	
ZSLNS2003-2.5		2.5						3.4	3.7	4.0	4.3	4.7	•	
ZSLNS2003-3		3						3.9	4.3	4.6	4.9	5.4	•	
ZSLNS2004-1	0.4	1	0.6	0.37	50	4	10.7	1.7	1.9	2.2	2.4	2.7	•	
ZSLNS2004-1.5		1.5						2.3	2.5	2.8	3.0	3.4	•	
ZSLNS2004-2		2						2.8	3.1	3.4	3.6	4.1	•	
ZSLNS2004-2.5		2.5						3.4	3.7	4.0	4.3	4.7	•	
ZSLNS2004-3		3						3.9	4.3	4.6	4.9	5.4	•	
ZSLNS2004-3.5		3.5						4.5	4.9	5.2	5.5	6.0	•	
ZSLNS2004-4		4						5.0	5.4	5.8	6.1	6.6	•	
ZSLNS2004-5		5						6.1	6.6	6.9	7.3	7.8	•	
ZSLNS2004-6	6	7.1	7.2	7.7	8.1	8.4	9.0	•						
ZSLNS2005-1	0.5	1	0.75	0.47	50	4	10.7	1.7	1.9	2.2	2.4	2.7	•	
ZSLNS2005-1.5		1.5						2.3	2.5	2.8	3.0	3.4	•	
ZSLNS2005-2		2						2.8	3.1	3.4	3.6	4.1	•	
ZSLNS2005-2.5		2.5						3.4	3.7	4.0	4.3	4.7	•	
ZSLNS2005-3		3						3.9	4.3	4.6	4.9	5.4	•	
ZSLNS2005-4		4						5.0	5.4	5.8	6.1	6.6	•	
ZSLNS2005-5		5						6.1	6.6	6.9	7.3	7.8	•	
ZSLNS2005-6		6						7.0	7.2	7.7	8.1	8.4	9.0	•
ZSLNS2005-8		8						9.3	9.9	10.3	10.7	11.4	•	
ZSLNS2006-2	0.6	2	0.9	0.57	50	4	9.6	2.8	3.1	3.4	3.6	4.1	•	
ZSLNS2006-4		4						5.0	5.4	5.8	6.1	6.6	•	
ZSLNS2006-6		6						6.9	7.2	7.7	8.1	8.4	9.0	•
ZSLNS2006-8		8						9.3	9.9	10.3	10.7	11.4	•	
ZSLNS2006-10		10						11.5	12.1	12.6	13.0	13.7	•	

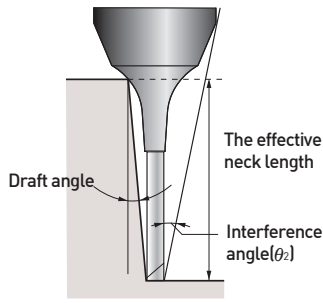

2 FLUTE, LONG NECK

- If the workpiece has draft angle, the interference length will be longer than the L_2 .
- Please refer to the effective neck length for the various draft angles.
- In addition, the angle at which the tool will interfere with the workpiece is shown as the "interference angle θ_2 ", and should also be referred to.

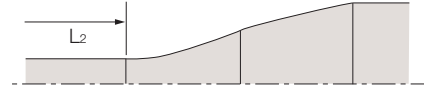

※The effective neck length shown is not an exact value and to avoid contact with the workpiece, we recommend the user control the precise value of this length.

EDP. No.	Dimension(mm)						Effective Neck Length					STOCK	
	D	L ₂	L ₁	d ₁	L ₃	d ₃	θ	0.5°	1°	1.5°	2°		3°
ZSLNS2007-2	0.7	2	1.05	0.67	50	4	9.6	2.8	3.1	3.4	3.6	4.1	•
ZSLNS2007-4		4					8.0	5.0	5.4	5.8	6.1	6.6	•
ZSLNS2007-6		6					6.9	7.2	7.7	8.1	8.4	9.0	•
ZSLNS2007-8		8					6.0	9.3	9.9	10.3	10.7	11.4	•
ZSLNS2007-10		10					5.3	11.5	12.1	12.6	13.0	13.7	•
ZSLNS2008-4	0.8	4	1.2	0.77	50	4	7.9	5.0	5.4	5.8	6.1	6.6	•
ZSLNS2008-6		6					6.8	7.2	7.7	8.1	8.4	9.0	•
ZSLNS2008-8		8					5.9	9.3	9.9	10.3	10.7	11.4	•
ZSLNS2008-10		10					5.2	11.5	12.1	12.6	13.0	13.7	•
ZSLNS2008-12		12			4.7		13.6	14.2	14.8	15.2	16.0	•	
ZSLNS2009-6	0.9	6	1.35	0.86	50	4	6.7	7.2	7.7	8.1	8.4	9.1	•
ZSLNS2009-8		8					5.8	9.4	9.9	10.4	10.7	11.4	•
ZSLNS2009-10		10					5.1	11.5	12.1	12.6	13.0	13.7	•
ZSLNS2009-12		12					4.6	13.6	14.3	14.8	15.2	16.0	•
ZSLNS2010-2	1	2	1.5	0.96	50	4	9.4	2.9	3.2	3.4	3.7	4.1	•
ZSLNS2010-4		4					7.7	5.1	5.5	5.8	6.1	6.6	•
ZSLNS2010-6		6					6.6	7.2	7.7	8.1	8.4	9.1	•
ZSLNS2010-8		8					5.7	9.4	9.9	10.4	10.7	11.4	•
ZSLNS2010-10		10					5.0	11.5	12.1	12.6	13.0	13.7	•
ZSLNS2010-12		12			4.5		13.6	14.3	14.8	15.2	16.0	•	
ZSLNS2010-14		14			4.1		15.7	16.4	17.0	17.4	18.7	•	
ZSLNS2010-16		16			3.8		17.8	18.6	19.1	19.6	21.3	•	
ZSLNS2010-20		20			3.2		22.0	22.8	23.5	24.0	26.6	•	
ZSLNS2012-6	1.2	6	1.8	1.15	50	4	6.3	7.3	7.7	8.1	8.5	9.1	•
ZSLNS2012-8		8					5.5	9.4	9.9	10.4	10.8	11.4	•
ZSLNS2012-10		10					4.8	11.5	12.1	12.6	13.0	13.7	•
ZSLNS2012-12		12					4.3	13.6	14.3	14.8	15.2	16.0	•
ZSLNS2012-16		16			3.6		17.8	18.6	19.2	19.7	21.3	•	
ZSLNS2014-6	1.4	6	2.1	1.34	50	4	6.1	7.3	7.8	8.1	8.5	9.1	•
ZSLNS2014-8		8					5.3	9.4	10.0	10.4	10.8	11.5	•
ZSLNS2014-10		10					4.6	11.6	12.1	12.6	13.0	13.8	•
ZSLNS2014-12		12					4.1	13.7	14.3	14.8	15.3	16.1	•
ZSLNS2014-14		14			3.7		15.8	16.5	17.0	17.5	18.7	•	
ZSLNS2014-16		16			3.4		17.9	18.6	19.2	19.7	21.4	•	

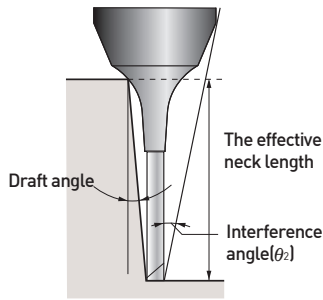

2 FLUTE, LONG NECK

- If the workpiece has draft angle, the interference length will be longer than the L_2 .
- Please refer to the effective neck length for the various draft angles.
- In addition, the angle at which the tool will interfere with the workpiece is shown as the "interference angle θ_2 ", and should also be referred to.

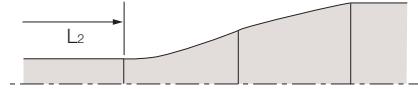

※The effective neck length shown is not an exact value and to avoid contact with the workpiece, we recommend the user control the precise value of this length.

EDP. No.	Dimension(mm)						Effective Neck Length					STOCK	
	D	L ₂	L ₁	d ₁	L ₃	d ₃	θ	0.5°	1°	1.5°	2°		3°
ZSLNS2015-4	1.5	4	2.25	1.44	50	4	7.2	5.2	5.5	5.9	6.2	6.7	•
ZSLNS2015-6		6					6.0	7.3	7.8	8.1	8.5	9.1	•
ZSLNS2015-8		8					5.1	9.4	10.0	10.4	10.8	11.5	•
ZSLNS2015-10		10					4.5	11.6	12.1	12.6	13.0	13.8	•
ZSLNS2015-12		12					4.0	13.7	14.3	14.8	15.3	16.1	•
ZSLNS2015-14		14			3.6		15.8	16.5	17.0	17.5	18.7	•	
ZSLNS2015-16		16			3.3		17.9	18.6	19.2	19.7	-	•	
ZSLNS2015-18		18			3.0		20.0	20.7	21.3	21.9	-	•	
ZSLNS2015-20		20			2.8		22.0	22.9	23.5	24.1	-	•	
ZSLNS2015-25		25			2.4		27.3	28.1	28.8	30.0	-	•	
ZSLNS2016-6		1.6			6		2.4	1.54	50	4	5.9	7.3	7.8
ZSLNS2016-8	8		5.0	9.4	10.0	10.4					10.8	11.5	•
ZSLNS2016-10	10		4.4	11.6	12.1	12.6					13.0	13.8	•
ZSLNS2016-12	12		3.9	13.7	14.3	14.8					15.3	16.1	•
ZSLNS2016-14	14		3.5	15.8	16.5	17.0			17.5		18.7	•	
ZSLNS2016-16	16		3.2	17.9	18.6	19.2			19.7		21.4	•	
ZSLNS2016-18	18		2.9	20.0	20.7	21.3			21.9		-	•	
ZSLNS2016-20	20		2.7	22.0	22.9	23.5			24.1		-	•	
ZSLNS2018-6	1.8	6	2.7	1.73	50	4	5.6	7.4	7.8	8.2	8.5	9.1	•
ZSLNS2018-8		8					4.8	9.5	10.0	10.4	10.8	11.5	•
ZSLNS2018-10		10					4.2	11.6	12.2	12.6	13.0	13.8	•
ZSLNS2018-12		12			3.7		13.7	14.3	14.8	15.3	16.1	•	
ZSLNS2018-14		14			3.3		15.8	16.5	17.0	17.5	18.8	•	
ZSLNS2018-16		16			3.0		17.9	18.6	19.2	19.7	-	•	
ZSLNS2018-18		18			2.7		20.0	20.7	21.3	21.9	-	•	
ZSLNS2018-20		20			2.5		22.1	22.9	23.5	24.1	-	•	
ZSLNS2020-4		2			4		3	1.92	50	4	6.5	5.3	5.6
ZSLNS2020-6	6		5.3	7.4	7.8	8.2					8.5	9.1	•
ZSLNS2020-8	8		4.5	9.5	10.0	10.4					10.8	11.5	•
ZSLNS2020-10	10		3.9	11.6	12.2	12.7			13.1		13.8	•	
ZSLNS2020-12	12		3.4	13.7	14.3	14.9			15.3		16.1	•	
ZSLNS2020-14	14		3.1	15.8	16.5	17.0			17.5		18.8	•	

- No interference

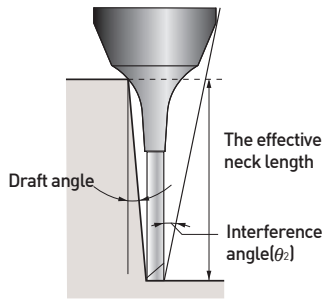

2 FLUTE, LONG NECK

- If the workpiece has draft angle, the interference length will be longer than the L_2 .
- Please refer to the effective neck length for the various draft angles.
- In addition, the angle at which the tool will interfere with the workpiece is shown as the "interference angle θ_2 ", and should also be referred to.

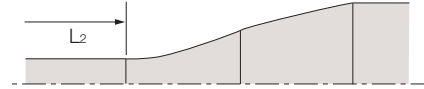

※The effective neck length shown is not an exact value and to avoid contact with the workpiece, we recommend the user control the precise value of this length.

EDP. No.	Dimension(mm)							Effective Neck Length					STOCK
	D	L ₂	L ₁	d ₁	L ₃	d ₃	θ	0.5°	1°	1.5°	2°	3°	
ZSLNS2020-16	2	16	3	1.92	55	4	2.8	17.9	18.6	19.2	19.7	-	•
ZSLNS2020-18		18			60		2.6	20.0	20.8	21.4	21.9	-	•
ZSLNS2020-20		20			65		2.4	22.1	22.9	23.5	24.1	-	•
ZSLNS2020-25		25			70		2.0	27.3	28.2	28.9	-	-	•
ZSLNS2020-30		30			2.8		32.5	33.4	34.4	-	-	•	
ZSLNS2025-8	2.5	8	3.75	2.4	50	4	3.7	9.6	10.1	10.5	10.9	11.5	•
ZSLNS2025-10		10			55		3.1	11.7	12.2	12.7	13.1	13.8	•
ZSLNS2025-12		12			60		2.7	13.8	14.4	14.9	15.3	-	•
ZSLNS2025-14		14			65		2.4	15.9	16.5	17.1	17.5	-	•
ZSLNS2025-16		16			70		2.2	18.0	18.7	19.2	19.7	-	•
ZSLNS2025-18		18			2.0		20.1	20.8	21.4	-	-	•	
ZSLNS2025-20		20			1.8		22.1	22.9	23.5	-	-	•	
ZSLNS2025-25		25			1.5		27.3	28.2	-	-	-	•	
ZSLNS2025-30		30			1.3		32.6	33.5	-	-	-	•	
ZSLNS2030-8	3	8	4.5	2.88	55	6	5.6	9.6	10.1	10.5	10.9	11.5	•
ZSLNS2030-10		10			60		5.0	11.7	12.3	12.7	13.1	13.8	•
ZSLNS2030-12		12			65		4.5	13.8	14.4	14.9	15.4	16.3	•
ZSLNS2030-14		14			70		4.1	15.9	16.6	17.1	17.6	18.9	•
ZSLNS2030-16		16			75		3.7	18.0	18.7	19.3	19.8	21.6	•
ZSLNS2030-18		18			80		3.4	20.1	20.8	21.4	21.9	24.2	•
ZSLNS2030-20		20			85		3.2	22.2	23.0	23.6	24.2	26.9	•
ZSLNS2030-25		25			90		2.7	27.4	28.2	28.9	30.2	-	•
ZSLNS2030-30		30			2.4		32.6	33.5	34.5	36.2	-	•	
ZSLNS2030-35		35			2.1		37.7	38.7	40.2	42.2	-	•	
ZSLNS2030-40		40			1.9		42.9	43.9	45.9	-	-	•	

- No interference

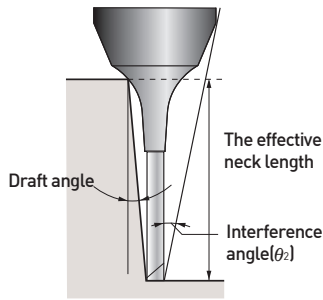

2 FLUTE, LONG NECK

- If the workpiece has draft angle, the interference length will be longer than the L_2 .
- Please refer to the effective neck length for the various draft angles.
- In addition, the angle at which the tool will interfere with the workpiece is shown as the "interference angle θ_2 ", and should also be referred to.

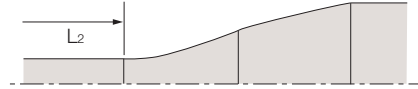

※The effective neck length shown is not an exact value and to avoid contact with the workpiece, we recommend the user control the precise value of this length.

EDP. No.	Dimension(mm)						Effective Neck Length					STOCK	
	D	L ₂	L ₁	d ₁	L ₃	d ₃	θ	0.5°	1°	1.5°	2°		3°
ZSLNS2040-12	4	12	6	3.85	60	6	3.4	13.9	14.5	15.0	15.4	16.3	•
ZSLNS2040-16		16					2.8	18.1	18.8	19.3	19.8	-	•
ZSLNS2040-20		20					2.3	22.3	23.0	23.6	24.3	-	•
ZSLNS2040-25		25			2.0		27.4	28.3	28.9	-	-	•	
ZSLNS2040-30		30			1.7		32.6	33.5	34.6	-	-	•	
ZSLNS2040-35		35			1.5		37.8	38.8	-	-	-	•	
ZSLNS2040-40		40			1.3		42.9	44.0	-	-	-	•	
ZSLNS2040-45		45			1.2		48.1	49.4	-	-	-	•	
ZSLNS2040-50		50			1.1		53.2	54.8	-	-	-	•	
ZSLNS2050-16		5			16		7.5	4.85	60	6	1.5	18.1	18.8
ZSLNS2050-20	20		1.3	22.3	23.0	-					-	-	•
ZSLNS2050-25	25		1.1	27.4	28.3	-			-		-	•	
ZSLNS2050-30	30		0.9	32.6	-	-			-		-	•	
ZSLNS2050-35	35		0.8	37.8	-	-			-		-	•	
ZSLNS2050-40	40		0.7	42.9	-	-			-		-	•	
ZSLNS2050-50	50		0.6	53.2	-	-			-		-	•	

— No interference

■ Tolerance

Diameter	Mill Dia. (mm)	Shank Dia.
0,1 ~ 0,5	0 ~ -0,012	h5
0,6 ~ 4	0 ~ -0,015	

※Items can be changed for quality improvement without notice.

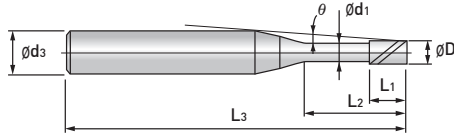

The effective neck length shown is not an exact value and to avoid contact with the workpiece, we recommend the user control the precise value of this length.

ZSLNS40....-.. series



EDP. No.	Dimension(mm)						Effective Neck Length					STOCK	
	D	L ₂	L ₁	d ₁	L ₃	d ₃	θ	0.5°	1°	1.5°	2°		3°
ZSLNS4010-4	1	4	1.5	0.96	50	4	7.7	5.1	5.5	5.8	6.1	6.6	•
ZSLNS4010-6		6					6.6	7.2	7.7	8.1	8.4	9.1	•
ZSLNS4010-8		8					5.7	9.4	9.9	10.4	10.7	11.4	•
ZSLNS4010-10		10					5.0	11.5	12.1	12.6	13.0	13.7	•
ZSLNS4015-4	1.5	4	2.25	1.44	50	4	7.2	5.2	5.5	5.9	6.2	6.7	•
ZSLNS4015-6		6					6.0	7.3	7.8	8.1	8.5	9.1	•
ZSLNS4015-8		8					5.1	9.4	10.0	10.4	10.8	11.5	•
ZSLNS4015-10		10					4.5	11.6	12.1	12.6	13.0	13.8	•
ZSLNS4015-12		12			4.0	13.7	14.3	14.8	15.3	16.1	•		
ZSLNS4015-14		14			3.6	15.8	16.5	17.0	17.5	18.7	•		
ZSLNS4015-16		16			3.3	17.9	18.6	19.2	19.7	-	•		
ZSLNS4015-18		18			3.0	20.0	20.7	21.3	21.9	-	•		
ZSLNS4015-20		20			2.8	22.0	22.9	23.5	24.1	-	•		
ZSLNS4015-25		25			2.4	27.3	28.1	28.8	30.0	-	•		
ZSLNS4020-4	2	4	3	1.92	50	4	6.5	5.3	5.6	5.9	6.2	6.7	•
ZSLNS4020-6		6					5.3	7.4	7.8	8.2	8.5	9.1	•
ZSLNS4020-8		8					4.5	9.5	10.0	10.4	10.8	11.5	•
ZSLNS4020-10		10					3.9	11.6	12.2	12.7	13.1	13.8	•
ZSLNS4020-12		12			3.4	13.7	14.3	14.9	15.3	16.1	•		
ZSLNS4020-14		14			3.1	15.8	16.5	17.0	17.5	18.8	•		
ZSLNS4020-16		16			2.8	17.9	18.6	19.2	19.7	-	•		
ZSLNS4020-18		18			2.6	20.0	20.8	21.4	21.9	-	•		
ZSLNS4020-20		20			2.4	22.1	22.9	23.5	24.1	-	•		
ZSLNS4020-25		25			2.0	27.3	28.2	28.9	-	-	•		
ZSLNS4020-30	30	1.7	32.5	33.4	34.4	-	-	•					
ZSLNS4025-8	2.5	8	3.75	2.4	50	4	3.7	9.6	10.1	10.5	10.9	11.5	•
ZSLNS4025-10		10					3.1	11.7	12.2	12.7	13.1	13.8	•
ZSLNS4025-12		12					2.7	13.8	14.4	14.9	15.3	-	•
ZSLNS4025-14		14					2.4	15.9	16.5	17.1	17.5	-	•
ZSLNS4025-16		16			2.2	18.0	18.7	19.2	19.7	-	•		
ZSLNS4025-18		18			2.0	20.1	20.8	21.4	-	-	•		
ZSLNS4025-20		20			1.8	22.1	22.9	23.5	-	-	•		
ZSLNS4025-25		25			1.5	27.3	28.2	-	-	-	•		
ZSLNS4025-30		30			1.3	32.6	33.5	-	-	-	•		

- No interference

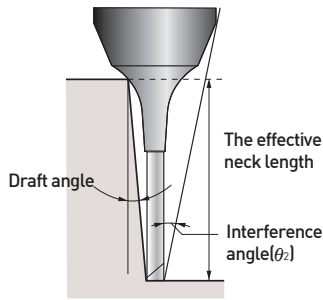

4 FLUTE, LONG NECK

- If the workpiece has draft angle, the interference length will be longer than the L_2 .
- Please refer to the effective neck length for the various draft angles.
- In addition, the angle at which the tool will interfere with the workpiece is shown as the "interference angle θ_2 ", and should also be referred to.

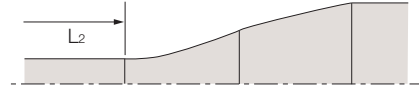

※The effective neck length shown is not an exact value and to avoid contact with the workpiece, we recommend the user control the precise value of this length.

EDP. No.	Dimension(mm)							Effective Neck Length					STOCK
	D	L ₂	L ₁	d ₁	L ₃	d ₃	θ	0.5°	1°	1.5°	2°	3°	
ZSLNS4030-8	3	8	4.5	2.88	55	6	5.6	9.6	10.1	10.5	10.9	11.5	•
ZSLNS4030-10		10					5.0	11.7	12.3	12.7	13.1	13.8	•
ZSLNS4030-12		12					4.5	13.8	14.4	14.9	15.4	16.3	•
ZSLNS4030-14		14			4.1		15.9	16.6	17.1	17.6	18.9	•	
ZSLNS4030-16		16			3.7		18.0	18.7	19.3	19.8	21.6	•	
ZSLNS4030-18		18			3.4		20.1	20.8	21.4	21.9	24.2	•	
ZSLNS4030-20		20			3.2		22.2	23.0	23.6	24.2	26.9	•	
ZSLNS4030-25		25			2.7		27.4	28.2	28.9	30.2	-	•	
ZSLNS4030-30		30			2.4		32.6	33.5	34.5	36.2	-	•	
ZSLNS4030-35		35			2.1		37.7	38.7	40.2	42.2	-	•	
ZSLNS4030-40		40			1.9		42.9	43.9	45.9	-	-	•	
ZSLNS4040-12		4			12		6	3.85	60	6	3.4	13.9	14.5
ZSLNS4040-16	16		2.8	18.1	18.8	19.3					19.8	-	•
ZSLNS4040-20	20		2.3	22.3	23.0	23.6			24.3		-	•	
ZSLNS4040-25	25		2.0	27.4	28.3	28.9			-		-	•	
ZSLNS4040-30	30		1.7	32.6	33.5	34.6			-		-	•	
ZSLNS4040-35	35		1.5	37.8	38.8	-			-		-	•	
ZSLNS4040-40	40		1.3	42.9	44.0	-			-		-	•	
ZSLNS4040-45	45		1.2	48.1	49.4	-			-		-	•	
ZSLNS4040-50	50		1.1	53.2	54.8	-			-		-	•	
ZSLNS4050-16	5	16	7.5	4.85	60	6	1.5	18.1	18.8	-	-	-	•
ZSLNS4050-20		20					1.3	22.3	23.0	-	-	-	•
ZSLNS4050-25		25			1.1		27.4	28.3	-	-	-	•	
ZSLNS4050-30		30			0.9		32.6	-	-	-	-	•	
ZSLNS4050-35		35			0.8		37.8	-	-	-	-	•	
ZSLNS4050-40		40			0.7		42.9	-	-	-	-	•	
ZSLNS4050-40		40			0.7		42.9	-	-	-	-	•	
ZSLNS4050-50		50			0.6		53.2	-	-	-	-	•	

- No interference

■ Tolerance

Diameter	Mill Dia. (mm)	Shank Dia.
0,1 ~ 0,5	0 ~ -0,012	h5
0,6 ~ 4	0 ~ -0,015	

※Items can be changed for quality improvement without notice.

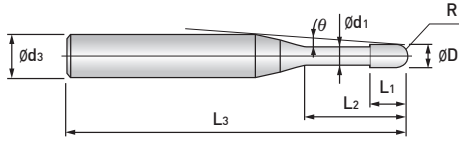

The effective neck length shown is not an exact value and to avoid contact with the workpiece, we recommend the user control the precise value of this length.

ZSLNB..... series

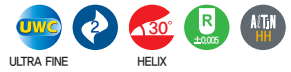

EDP. No.	Dimension(mm)							Effective Neck Length					STOCK	
	R	D	L ₂	L ₁	d ₁	L ₃	d ₃	θ	0.5°	1°	1.5°	2°		3°
ZSLNB2001-0.2	0.05	0.1	0.2	0.08	0.08	45	4	11.8	0.3	0.3	0.3	0.4	0.4	•
ZSLNB2001-0.3			0.3						0.4	0.4	0.5	0.5	0.5	•
ZSLNB2001-0.5			0.5						0.6	0.7	0.7	0.7	0.8	•
ZSLNB2002-0.5	0.1	0.2	0.5	0.15	0.17	50	4	11.5	1.2	1.3	1.5	1.6	2.0	•
ZSLNB2002-1			1						1.7	1.9	2.1	2.3	2.7	•
ZSLNB2002-1.5			1.5						2.3	2.5	2.8	3.0	3.4	•
ZSLNB2002-2			2						2.8	3.1	3.4	3.6	4.1	•
ZSLNB2002-2.5			2.5						3.4	3.7	4.0	4.2	4.7	•
ZSLNB2002-3.0			3						3.9	4.3	4.6	4.9	5.4	•
ZSLNB2003-1			0.15						0.3	1	0.25	0.27	50	4
ZSLNB2003-1.5	1.5	2.3		2.5	2.7	3.0	3.4	•						
ZSLNB2003-2	2	2.8		3.1	3.4	3.6	4.0	•						
ZSLNB2003-2.5	2.5	3.4		3.7	4.0	4.2	4.7	•						
ZSLNB2003-3	3	3.9		4.3	4.6	4.8	5.3	•						
ZSLNB2004-1	0.2	0.4	1	0.3	0.37	50	4	11.0	1.7	1.9	2.1	2.3	2.7	•
ZSLNB2004-1.5			1.5						2.3	2.5	2.7	2.9	3.4	•
ZSLNB2004-2			2						2.8	3.1	3.4	3.6	4.0	•
ZSLNB2004-2.5			2.5						3.4	3.7	4.0	4.2	4.7	•
ZSLNB2004-3			3						3.9	4.3	4.6	4.8	5.3	•
ZSLNB2004-3.5			3.5						4.5	4.8	5.2	5.4	6.0	•
ZSLNB2004-4			4						5.0	5.4	5.7	6.0	6.6	•
ZSLNB2004-4.5			4.5						5.6	6.0	6.3	6.6	7.2	•
ZSLNB2005-1	0.25	0.5	1	0.35	0.47	50	4	11.0	1.7	1.9	2.1	2.3	2.6	•
ZSLNB2005-2			2						2.8	3.1	3.3	3.6	4.0	•
ZSLNB2005-3			3						3.9	4.3	4.6	4.8	5.3	•
ZSLNB2005-4			4						5.0	5.4	5.7	6.0	6.6	•
ZSLNB2005-5			5						6.1	6.5	6.9	7.2	7.8	•
ZSLNB2005-6			6						7.1	7.6	8.0	8.4	9.0	•
ZSLNB2005-7			7						8.1	8.6	9.0	9.4	10.0	•
ZSLNB2005-8			8						9.3	9.9	10.3	10.7	11.4	•

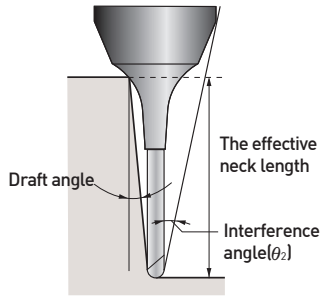

2 FLUTE, LONG NECK

- If the workpiece has draft angle, the interference length will be longer than the L_2 .
- Please refer to the effective neck length for the various draft angles.
- In addition, the angle at which the tool will interfere with the workpiece is shown as the "interference angle θ_2 ", and should also be referred to.



※The effective neck length shown is not an exact value and to avoid contact with the workpiece, we recommend the user control the precise value of this length.

EDP. No.	Dimension(mm)								Effective Neck Length					STOCK
	R	D	L ₂	L ₁	d ₁	L ₃	d ₃	θ	0.5°	1°	1.5°	2°	3°	
ZSLNB2006-1	0.3	0.6	1	0.4	0.57	50	4	11.0	1.7	1.9	2.1	2.3	2.6	•
ZSLNB2006-2			2					9.9	2.8	3.1	3.3	3.6	4.0	•
ZSLNB2006-3			3					9.0	3.9	4.3	4.5	4.8	5.3	•
ZSLNB2006-4			4					8.3	5.0	5.4	5.7	6.0	6.6	•
ZSLNB2006-5			5					7.6	6.1	6.5	6.9	7.2	7.8	•
ZSLNB2006-6			6					7.1	7.2	7.6	8.0	8.4	9.0	•
ZSLNB2006-7			7					6.6	8.3	8.8	9.2	9.5	10.2	•
ZSLNB2006-8			8					6.2	9.3	9.9	10.3	10.7	11.4	•
ZSLNB2006-9			9					5.8	10.4	10.9	11.4	11.8	12.5	•
ZSLNB2006-10			10					5.5	11.4	12.0	12.5	12.9	13.7	•
ZSLNB2006-12			12					5.0	13.6	14.2	14.7	15.2	16.0	•
ZSLNB2008-2			0.4					0.8	2	0.5	0.77	50	4	9.9
ZSLNB2008-4	4	8.2		5.0	5.4	5.7	6.0		6.5					•
ZSLNB2008-5	5	7.5		6.1	6.5	6.9	7.2		7.8					•
ZSLNB2008-6	6	7.0		7.2	7.6	8.0	8.4		9.0					•
ZSLNB2008-8	8	6.1		9.3	9.8	10.3	10.7		11.3					•
ZSLNB2008-10	10	5.4	11.4	12.0	12.5	12.9	13.7	•						
ZSLNB2010-2	0.5	1	2	0.8	0.96	50	4	9.9	2.9	3.1	3.3	3.5	4.0	•
ZSLNB2010-3			3					8.9	4.0	4.3	4.5	4.8	5.3	•
ZSLNB2010-4			4					8.1	5.0	5.4	5.7	6.0	6.5	•
ZSLNB2010-5			5					7.4	6.1	6.5	6.9	7.2	7.8	•
ZSLNB2010-6			6					6.8	7.2	7.7	8.0	8.4	9.0	•
ZSLNB2010-7			7					6.3	8.3	8.8	9.2	9.5	10.2	•
ZSLNB2010-8			8			5.9		9.3	9.9	10.3	10.7	11.3	•	
ZSLNB2010-9			9			5.5		10.4	11.0	11.4	11.8	12.5	•	
ZSLNB2010-10			10			5.2		11.5	12.0	12.5	12.9	13.7	•	
ZSLNB2010-12			12			4.6		13.6	14.2	14.7	15.2	15.9	•	
ZSLNB2010-14			14			4.2		15.7	16.4	16.9	17.4	18.5	•	
ZSLNB2010-16			16			3.8		17.8	18.5	19.1	19.6	21.2	•	
ZSLNB2010-18	18	3.5	19.9	20.7	21.3	21.8	23.8	•						
ZSLNB2010-20	20	3.3	22.0	22.8	23.4	24.0	26.5	•						
ZSLNB2012-4	0.6	1.2	4	1.1	1.15	50	4	7.9	5.1	5.4	5.7	6.0	6.5	•
ZSLNB2012-6			6					6.6	7.2	7.7	8.0	8.4	9.0	•
ZSLNB2012-8			8					5.7	9.4	9.9	10.3	10.7	11.3	•
ZSLNB2012-10			10					5.0	11.5	12.1	12.5	12.9	13.7	•
ZSLNB2012-12			12			4.5		13.6	14.2	14.7	15.2	15.9	•	

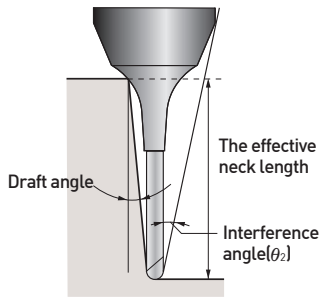

2 FLUTE, LONG NECK

- If the workpiece has draft angle, the interference length will be longer than the L_2 .
- Please refer to the effective neck length for the various draft angles.
- In addition, the angle at which the tool will interfere with the workpiece is shown as the "interference angle θ_2 ", and should also be referred to.



※The effective neck length shown is not an exact value and to avoid contact with the workpiece, we recommend the user control the precise value of this length.

EDP. No.	Dimension(mm)								Effective Neck Length					STOCK
	R	D	L ₂	L ₁	d ₁	L ₃	d ₃	θ	0.5°	1°	1.5°	2°	3°	
ZSLNB2014-8	0.7	1.4	8	1.3	1.34	50	4	5.5	9.4	9.9	10.3	10.7	11.3	•
ZSLNB2014-12			12			55		4.3	13.6	14.2	14.7	15.2	15.9	•
ZSLNB2014-16			16			3.5		17.8	18.5	19.1	19.6	21.2	•	
ZSLNB2015-4	0.75	1.5	4	1.35	1.44	50	4	7.7	5.1	5.4	5.7	6.0	6.5	•
ZSLNB2015-6			6					6.4	7.3	7.7	8.0	8.4	9.0	•
ZSLNB2015-8			8					5.4	9.4	9.9	10.3	10.7	11.3	•
ZSLNB2015-10			10					4.7	11.5	12.1	12.5	12.9	13.7	•
ZSLNB2015-12			12			4.2		13.6	14.2	14.7	15.2	15.9	•	
ZSLNB2015-14			14			3.8		15.7	16.4	16.9	17.4	18.5	•	
ZSLNB2015-16			16			3.4		17.8	18.5	19.1	19.6	21.1	•	
ZSLNB2015-20			20			2.9		22.0	22.8	23.4	24.0	-	•	
ZSLNB2016-8	0.8	1.6	8	1.4	1.54	50	4	5.3	9.4	9.9	10.3	10.7	11.3	•
ZSLNB2016-10			10			4.6		11.5	12.1	12.5	12.9	13.7	•	
ZSLNB2016-12			12			4.1		13.6	14.2	14.7	15.2	15.9	•	
ZSLNB2016-16			16			3.3		17.8	18.5	19.1	19.6	21.1	•	
ZSLNB2016-20			20			2.8		22.0	22.8	23.4	24.0	-	•	
ZSLNB2018-8	0.9	1.8	8	1.6	1.73	50	4	5.1	9.4	9.9	10.3	10.7	11.3	•
ZSLNB2018-12			12			3.9		13.7	14.3	14.7	15.2	15.9	•	
ZSLNB2018-16			16			3.1		17.9	18.6	19.1	19.6	21.1	•	
ZSLNB2018-20			20			2.6		22.0	22.8	23.4	24.0	-	•	
ZSLNB2020-3	1	2	3	*3	1.92	50	4	8.3	4.1	4.4	4.6	4.8	5.2	•
ZSLNB2020-4			4					7.3	5.2	5.5	5.8	6.0	6.5	•
ZSLNB2020-6			6					5.8	7.3	7.7	8.1	8.4	9.0	•
ZSLNB2020-8			8					4.9	9.5	9.9	10.3	10.7	11.3	•
ZSLNB2020-10			10					4.2	11.6	12.1	12.6	12.9	13.6	•
ZSLNB2020-12			12			3.7		13.7	14.3	14.8	15.2	15.9	•	
ZSLNB2020-14			14			3.2		15.8	16.4	16.9	17.4	18.5	•	
ZSLNB2020-16			16			2.9		17.9	18.6	19.1	19.6	-	•	
ZSLNB2020-18			18			2.7		20.0	20.7	21.3	21.8	-	•	
ZSLNB2020-20			20			2.4		22.1	22.8	23.4	24.0	-	•	
ZSLNB2020-22			22			2.3		24.1	24.9	25.6	26.3	-	•	
ZSLNB2020-25			25			2.0		27.3	28.1	28.8	-	-	•	
ZSLNB2020-30			30			1.7		32.4	33.4	34.2	-	-	•	

- No interference

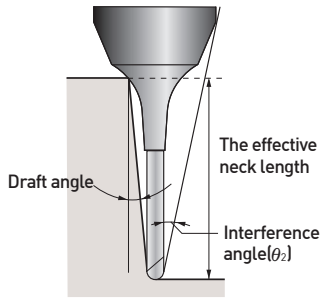

2 FLUTE, LONG NECK

- If the workpiece has draft angle, the interference length will be longer than the L_2 .
- Please refer to the effective neck length for the various draft angles.
- In addition, the angle at which the tool will interfere with the workpiece is shown as the "interference angle θ_2 ", and should also be referred to.

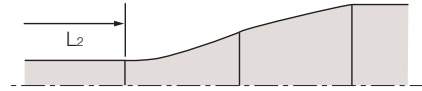

※The effective neck length shown is not an exact value and to avoid contact with the workpiece, we recommend the user control the precise value of this length.

EDP. No.	Dimension(mm)								Effective Neck Length					STOCK
	R	D	L ₂	L ₁	d ₁	L ₃	d ₃	θ	0.5°	1°	1.5°	2°	3°	
ZSLNB2020-35	1	2	35	*3	1.92	75	4	1.5	37.6	38.6	-	-	-	•
ZSLNB2020-40			40			80		1.4	42.8	43.8	-	-	-	•
ZSLNB2025-10	1.25	2.5	10	4	2.4	50	4	3.4	11.6	12.1	12.6	13	13.6	•
ZSLNB2025-16			16			55		2.3	17.9	18.6	19.1	19.6	-	•
ZSLNB2025-20			20			60		1.9	22.1	22.8	23.5	-	-	•
ZSLNB2030-8	1.5	3	8	*4	2.88	55	6	6.2	9.6	10.0	10.4	10.7	11.3	•
ZSLNB2030-10			10					5.5	11.7	12.2	12.6	13.0	13.6	•
ZSLNB2030-13			13			4.6		14.8	15.4	15.9	16.3	17.1	•	
ZSLNB2030-16			16			4.0		18.0	18.6	19.1	19.6	21.1	•	
ZSLNB2030-18			18			3.6		20.0	20.7	21.3	21.8	23.7	•	
ZSLNB2030-20			20			3.4		22.1	22.9	23.5	24.0	26.4	•	
ZSLNB2030-25			25			2.8		27.3	28.2	28.8	29.9	-	•	
ZSLNB2030-30			30			2.5		32.5	33.4	34.3	35.9	-	•	
ZSLNB2030-35			35			2.2		37.7	38.7	40.0	41.9	-	•	
ZSLNB2040-10			2			4		10	*5	3.9	55	6	4.5	11.6
ZSLNB2040-13	13	3.6		14.7	15.3		15.8	16.2					17.0	•
ZSLNB2040-16	16	3.1		17.9	18.5		19.1	19.5			20.9		•	
ZSLNB2040-20	20	2.5		22.1	22.8		23.4	23.9			-		•	
ZSLNB2040-25	25	2.1		27.3	28.1		28.8	29.8			-		•	
ZSLNB2040-30	30	1.8		32.4	33.4		34.2	-			-		•	
ZSLNB2040-35	35	1.6		37.6	38.6		39.9	-			-		•	
ZSLNB2040-40	40	1.4		42.8	43.8		-	-			-		•	
ZSLNB2040-45	45	1.2		47.9	49.1		-	-			-		•	
ZSLNB2040-50	50	1.1		53.1	54.5		-	-			-		•	
ZSLNB2050-20	2.5	5	20	*6	4.9	65	6	1.4	22.0	22.8	-	-	-	•
ZSLNB2050-25			25			70		1.2	27.2	28.1	-	-	-	•
ZSLNB2050-30			30			75		1.0	32.4	-	-	-	-	•
ZSLNB2050-35			35			80		0.8	42.8	-	-	-	-	•
ZSLNB2050-40			40			90		0.7	42.8	-	-	-	-	•

- No interference

■ Tolerance

Radius (mm)	Shank Dia.
±0.005	h5

※Items can be changed for quality improvement without notice.

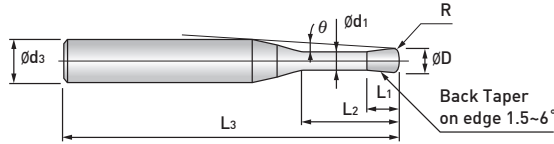

The effective neck length shown is not an exact value and to avoid contact with the workpiece, we recommend the user control the precise value of this length.

ZSLNR..... series

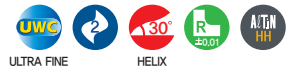

EDP. No.	Dimension(mm)							Effective Neck Length					STOCK		
	D	R	L ₂	L ₁	d ₁	L ₃	d ₃	θ	0.5°	1°	1.5°	2°		3°	
ZSLNR2002-0.5-005	0.2	0.05	0.5	0.15	0.17	50	4	11.4	0.9	1.0	1.0	1.1	1.2	•	
ZSLNR2002-1-005			1						10.9	1.6	1.7	1.9	2.0	2.3	•
ZSLNR2002-1.5-005			1.5						10.3	2.1	2.3	2.5	2.7	3.0	•
ZSLNR2002-2-005			2						9.9	2.8	3.1	3.4	3.6	4.1	•
ZSLNR2003-1-005	0.3	0.05	1	0.25	0.27	50	4	10.8	1.4	1.5	1.6	1.7	1.9	•	
ZSLNR2003-1.5-005			1.5						10.3	2.1	2.3	2.5	2.7	3.0	•
ZSLNR2003-2-005			2						9.8	2.7	2.9	3.1	3.3	3.6	•
ZSLNR2003-2.5-005			2.5						9.4	3.2	3.5	3.7	3.9	4.3	•
ZSLNR2003-3-005			3						9.0	3.9	4.3	4.6	4.9	5.4	•
ZSLNR2004-1-005	0.4	0.05	1	0.3	0.37	50	4	10.8	1.4	1.5	1.6	1.7	1.9	•	
ZSLNR2004-1.5-005			1.5						10.3	2.0	2.1	2.2	2.3	2.5	•
ZSLNR2004-2-005			2						9.8	2.7	2.9	3.1	3.3	3.6	•
ZSLNR2004-2.5-005			2.5						9.4	3.2	3.5	3.7	3.9	4.3	•
ZSLNR2004-3-005			3						9.0	3.8	4.0	4.3	4.5	4.9	•
ZSLNR2004-3.5-005			3.5						8.6	4.3	4.6	4.9	5.1	5.5	•
ZSLNR2004-4-005		4	8.3	5.0	5.4	5.8	6.1	6.6	•						
ZSLNR2004-2-01		0.1	2	0.3	0.37	50	4	10.8	1.4	1.5	1.6	1.7	1.9	•	
ZSLNR2004-3-01			3						9.8	2.7	2.9	3.1	3.3	3.6	•
ZSLNR2004-4-01			4						9.0	3.8	4.0	4.3	4.5	4.9	•
ZSLNR2004-4-01	4		8.3						5.0	5.4	5.8	6.1	6.6	•	
ZSLNR2005-1-005	0.5	0.05	1	0.35	0.47	50	4	10.8	1.4	1.5	1.6	1.7	1.9	•	
ZSLNR2005-2-005			2						9.7	2.5	2.6	2.8	2.9	3.1	•
ZSLNR2005-3-005			3						8.9	3.8	4.0	4.3	4.5	4.9	•
ZSLNR2005-4-005			4						8.2	4.8	5.2	5.4	5.7	6.1	•
ZSLNR2005-5-005			5						7.6	6.1	6.6	6.9	7.3	7.8	•
ZSLNR2005-6-005			6						7.0	7.2	7.7	8.1	8.4	9.0	•
ZSLNR2005-1-01		0.1	1	0.35	0.47	50	4	10.8	1.4	1.5	1.6	1.7	1.9	•	
ZSLNR2005-2-01			2						9.8	2.5	2.6	2.8	2.9	3.1	•
ZSLNR2005-3-01			3						8.9	3.8	4.0	4.3	4.5	4.9	•
ZSLNR2005-3-01			3						8.9	3.8	4.0	4.3	4.5	4.9	•

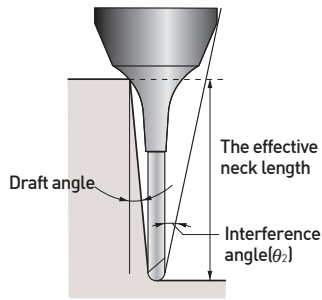

2 FLUTE, LONG NECK BACK DRAFT TYPE

- If the workpiece has draft angle, the interference length will be longer than the L_2 .
- Please refer to the effective neck length for the various draft angles.
- In addition, the angle at which the tool will interfere with the workpiece is shown as the "interference angle θ_2 ", and should also be referred to.

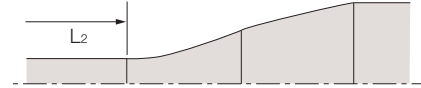

※The effective neck length shown is not an exact value and to avoid contact with the workpiece, we recommend the user control the precise value of this length.

EDP. No.	Dimension(mm)								Effective Neck Length					STOCK
	D	R	L ₂	L ₁	d ₁	L ₃	d ₃	θ	0.5°	1°	1.5°	2°	3°	
ZSLNR2005-4-01	0.5	0.1	4	0.35	0.47	50	4	8.2	4.8	5.2	5.4	5.7	6.1	•
ZSLNR2005-5-01			5					7.6	6.1	6.5	6.9	7.2	7.8	•
ZSLNR2005-6-01			6					7.1	7.2	7.7	8.1	8.4	9.0	•
ZSLNR2006-2-01	0.6	0.1	2	0.4	0.57	50	4	9.7	2.5	2.6	2.8	2.9	3.1	•
ZSLNR2006-4-01			4					8.1	4.8	5.2	5.4	5.7	6.1	•
ZSLNR2006-6-01			6					7.0	7.2	7.7	8.1	8.4	9.0	•
ZSLNR2006-8-01			8					6.1	9.3	9.9	10.3	10.7	11.4	•
ZSLNR2006-10-01			10					5.5	11.5	12.1	12.5	13.0	13.7	•
ZSLNR2008-4-01	0.8	0.1	4	0.5	0.77	50	4	8.0	4.8	5.2	5.4	5.7	6.1	•
ZSLNR2008-6-01			6					6.8	7.0	7.4	7.7	7.9	8.4	•
ZSLNR2008-8-01			8					5.9	9.3	9.9	10.3	10.7	11.4	•
ZSLNR2008-12-01		12	4.7			13.6		14.2	14.7	15.2	16.0	•		
ZSLNR2008-4-02		0.2	4			50		8.0	4.8	5.1	5.4	5.6	6.1	•
ZSLNR2008-6-02			6					6.9	7.0	7.3	7.7	7.9	8.4	•
ZSLNR2010-4-01	1	0.1	4	0.8	0.94	50	4	7.7	4.7	4.9	5.1	5.2	5.5	•
ZSLNR2010-6-01			6					6.6	7.1	7.4	7.7	8.0	8.5	•
ZSLNR2010-8-01			8					5.7	9.2	9.6	9.9	10.2	10.8	•
ZSLNR2010-10-01			10					5.1	11.6	12.1	12.6	13.0	13.7	•
ZSLNR2010-12-01			12					4.5	13.7	14.3	14.8	15.3	16.0	•
ZSLNR2010-16-01			16					3.8	17.9	18.6	19.2	19.7	21.3	•
ZSLNR2010-20-01		20	3.2			22.0		22.8	23.5	24.0	26.7	•		
ZSLNR2010-4-02		0.2	4			50		7.8	4.7	4.9	5.1	5.2	5.5	•
ZSLNR2010-6-02			6					6.6	7.1	7.4	7.7	8.0	8.5	•
ZSLNR2010-8-02			8					5.8	9.2	9.6	9.9	10.2	10.8	•
ZSLNR2010-10-02			10					5.1	11.6	12.1	12.6	13.0	13.7	•
ZSLNR2010-12-02			12					4.6	13.7	14.3	14.8	15.2	16.0	•
ZSLNR2010-16-02	16		3.8	17.9	18.6		19.2	19.7	21.3	•				
ZSLNR2010-20-02	20	3.2	22.0	22.8	23.5	24.0	26.6	•						

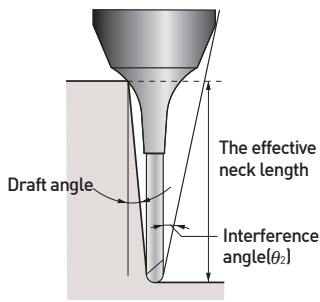

2 FLUTE, LONG NECK BACK DRAFT TYPE

- If the workpiece has draft angle, the interference length will be longer than the L_2 .
- Please refer to the effective neck length for the various draft angles.
- In addition, the angle at which the tool will interfere with the workpiece is shown as the "interference angle θ_z ", and should also be referred to.



※The effective neck length shown is not an exact value and to avoid contact with the workpiece, we recommend the user control the precise value of this length.

EDP. No.	Dimension(mm)								Effective Neck Length					STOCK			
	D	R	L ₂	L ₁	d ₁	L ₃	d ₃	θ	0.5°	1°	1.5°	2°	3°				
ZSLNR2010-6-03	1	0.3	6	0.8	0.94	50	4	6.7	7.1	7.4	7.7	8.0	8.4	•			
ZSLNR2010-10-03			10					5.1	11.5	12.1	12.6	13.0	13.7	•			
ZSLNR2010-16-03			16			3.8		17.9	18.6	19.1	19.6	21.3	•				
ZSLNR2010-20-03			20			3.2		22.0	22.8	23.5	24.0	26.6	•				
ZSLNR2015-4-01	1.5	0.1	4	1.35	1.42	50	4	7.2	4.8	4.9	5.1	5.3	5.5	•			
ZSLNR2015-8-01			8					5.2	9.2	9.6	10.0	10.3	10.8	•			
ZSLNR2015-12-01			12			4.0		13.4	13.9	14.3	14.7	16.1	•				
ZSLNR2015-15-01			15			3.5		16.9	17.6	18.1	18.6	20.1	•				
ZSLNR2015-20-01		20	2.8			22.1		22.9	23.5	24.1	-	•					
ZSLNR2015-4-02		0.2	4			1.35		1.42	50	4	7.3	4.7	4.9	5.1	5.3	5.5	•
ZSLNR2015-8-02			8								5.2	9.2	9.6	10.0	10.3	10.8	•
ZSLNR2015-12-02			12						4.1		13.4	13.9	14.3	14.7	16.1	•	
ZSLNR2015-15-02			15						3.5		16.9	17.5	18.1	18.6	20.0	•	
ZSLNR2015-20-02		20	2.8			22.1		22.9	23.5	24.1	-	•					
ZSLNR2015-8-03		0.3	8			1.35		1.42	50	4	5.2	9.2	9.6	10.0	10.3	10.8	•
ZSLNR2015-15-03			15								3.5	16.9	17.5	18.1	18.6	20.0	•
ZSLNR2015-20-03	20		2.8	22.1	22.9		23.5		24.0		-	•					
ZSLNR2020-6-02	2		0.2	6	1.7		1.92		50		4	5.4	6.8	7.1	7.3	7.5	8.1
ZSLNR2020-8-02		8		4.6		8.9		9.2		9.4		9.7	10.8	•			
ZSLNR2020-12-02		12		3.5		13.4		13.9	14.3	14.7		16.1	•				
ZSLNR2020-16-02		16		2.8		17.6		18.1	18.6	19.3		-	•				
ZSLNR2020-20-02		20		2.4		22.1		22.9	23.5	24.1		-	•				
ZSLNR2020-25-02		25		2.0		27.3		28.2	28.8	-		-	•				
ZSLNR2020-30-02		30	1.7	32.5		33.4		34.4	-	-		•					
ZSLNR2020-8-03		0.3	8	1.7		1.92		50	4	4.6		8.9	9.2	9.4	9.7	10.7	•
ZSLNR2020-16-03			16							2.8		17.6	18.1	18.6	19.3	-	•
ZSLNR2020-20-03			20					2.4		22.1		22.9	23.5	24.0	-	•	
ZSLNR2020-6-05			0.5					6		1.7		1.92	50	4	5.5	6.8	7.1
ZSLNR2020-8-05		8		4.7		8.9		9.2	9.4						9.6	10.7	•

— No interference

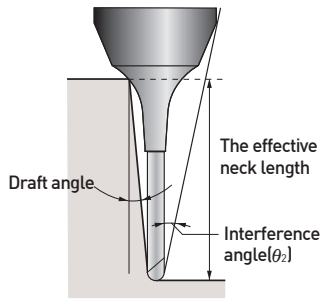

2 FLUTE, LONG NECK BACK DRAFT TYPE

- If the workpiece has draft angle, the interference length will be longer than the L_2 .
- Please refer to the effective neck length for the various draft angles.
- In addition, the angle at which the tool will interfere with the workpiece is shown as the "interference angle θ_2 ", and should also be referred to.



※The effective neck length shown is not an exact value and to avoid contact with the workpiece, we recommend the user control the precise value of this length.

EDP. No.	Dimension(mm)								Effective Neck Length					STOCK	
	D	R	L ₂	L ₁	d ₁	L ₃	d ₃	θ	0.5°	1°	1.5°	2°	3°		
ZSLNR2020-12-05	2	0.5	12	1.7	1.92	55	4	3.5	13.4	13.9	14.3	14.6	16.0	●	
ZSLNR2020-16-05			16					2.9	17.6	18.1	18.6	19.2	-	●	
ZSLNR2020-20-05			20					2.4	22.1	22.9	23.5	24.0	-	●	
ZSLNR2020-25-05			25					2.0	27.3	28.1	28.8	-	-	●	
ZSLNR2020-30-05		30	1.7			32.5		33.4	34.3	-	-	●			
ZSLNR2020-8-08		0.8	8			50		4.8	8.9	9.2	9.4	9.6	10.6	●	
ZSLNR2020-16-08			16			55		2.9	17.6	18.1	18.6	19.2	-	●	
ZSLNR2020-20-08			20			60		2.4	22.1	22.8	23.5	24.0	-	●	
ZSLNR2030-8-02	3		0.2	8	2.5	2.86	55	6	5.7	9.0	9.3	9.5	9.9	10.9	●
ZSLNR2030-12-02		12		60					4.5	13.1	13.5	14.0	14.7	16.2	●
ZSLNR2030-16-02		16		65					3.8	17.7	18.2	18.7	19.5	21.6	●
ZSLNR2030-20-02		20		75					3.2	21.8	22.4	23.1	24.2	26.9	●
ZSLNR2030-30-02		30		80					2.4	32.6	33.5	34.5	36.2	-	●
ZSLNR2030-35-02		35		80					2.1	37.7	38.7	40.2	42.2	-	●
ZSLNR2030-8-03		0.3	8	55			5.7		9.0	9.3	9.5	9.9	10.9	●	
ZSLNR2030-16-03			16	60			3.8		17.7	18.2	18.7	19.4	21.5	●	
ZSLNR2030-20-03			20	65			3.2		21.8	22.4	23.1	24.2	26.8	●	
ZSLNR2030-30-03			30	75			2.4		32.6	33.5	34.5	36.2	-	●	
ZSLNR2030-8-05		0.5	8	55			5.8		9.0	9.3	9.5	9.8	10.8	●	
ZSLNR2030-12-05			12	60			4.6		13.1	13.5	13.9	14.6	16.2	●	
ZSLNR2030-16-05			16	65			3.8		17.7	18.2	18.7	19.4	21.5	●	
ZSLNR2030-20-05			20	75			3.2		21.8	22.4	23.1	24.2	26.8	●	
ZSLNR2030-30-05			30	80			2.4		32.6	33.5	34.5	36.1	-	●	
ZSLNR2030-35-05			35	80			2.1		37.7	38.7	40.2	42.1	-	●	

— No interference

■ Tolerance

Mill Dia. (mm)	Shank Dia.
0 ~ -0,015	h5

※Items can be changed for quality improvement without notice.

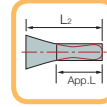
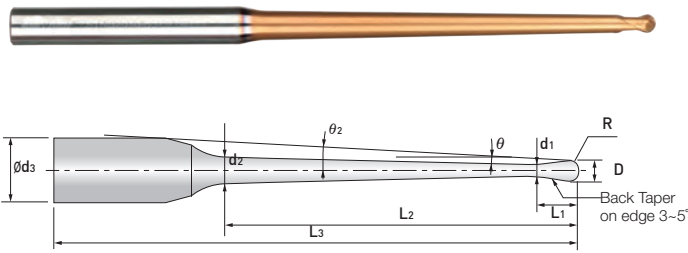

The effective neck length shown is not an exact value and to avoid contact with the workpiece, we recommend the user control the precise value of this length.

※R2 or higher is not applied to Back draft type.

ZSTNB20... series



EDP. No.	Dimension(mm)										Effective Neck Length					STOCK	
	R	D	L ₂	θ	L ₁	d ₁	d ₂	L ₃	d ₃	App. L	θ_2	0.5°	1°	1.5°	2°		3°
ZSTNB2002-1-04	0.1	0.2	1	0.4	0.15	0.17	0.18	50	4	1.35	10.9	1.5	1.7	1.8	2.0	2.3	
ZSTNB2002-1.5-04			1.5	0.4			0.19			1.77	10.4	2.0	2.2	2.4	2.6	2.9	
ZSTNB2002-2-09			2	0.9			0.23			1.10	10.1	x	2.8	3.1	3.4	3.9	
ZSTNB2002-2.5-09			2.5	0.9			0.24			1.10	9.6	x	3.3	3.7	4.0	4.5	
ZSTNB2003-2-04	0.15	0.3	2	0.4	0.25	0.28	0.29	50	4	2.19	10.0	2.5	2.8	3.0	3.2	3.5	
ZSTNB2003-3-09			3	0.9			0.36			1.20	9.3	x	3.8	4.2	4.5	5.1	
ZSTNB2003-4-09			4	0.9			0.39			1.20	8.6	x	4.8	5.3	5.7	6.3	
ZSTNB2004-2-04	0.2	0.4	2	0.4	0.3	0.37	0.39	50	4	2.20	10.0	2.5	2.8	3.0	3.2	3.5	
ZSTNB2004-3-04			3	0.4			0.41			2.44	9.1	3.6	3.9	4.1	4.4	4.8	
ZSTNB2004-4-04			4	0.4			0.42			2.44	8.4	4.7	5.2	5.6	5.9	6.5	
ZSTNB2004-4-09			4	0.9			0.49			1.25	8.5	x	4.8	5.3	5.7	6.3	
ZSTNB2004-5-04			5	0.4			0.44			2.44	7.8	5.7	6.3	6.7	7.1	7.7	
ZSTNB2004-5-09			5	0.9			0.52			1.25	7.9	x	5.9	6.4	6.8	7.5	
ZSTNB2005-4-04	0.25	0.5	4	0.4	0.35	0.47	0.52	50	4	2.49	8.4	4.6	5.0	5.3	5.5	5.9	
ZSTNB2005-8-09			8	0.9			0.71			1.30	6.5	x	8.9	9.6	10.1	10.9	
ZSTNB2005-12-09			12				0.84			1.30	5.3	x	13.0	13.9	14.5	15.4	
ZSTNB20054-2-04	0.27	0.54	2	0.4	0.37	0.52	0.54	50	4	1.80	10.0	2.3	2.5	2.7	2.8	3.0	
ZSTNB20054-4-04			4				0.57			1.80	8.4	4.5	4.9	5.2	5.5	5.9	
ZSTNB20054-5-04			5				0.59			1.80	7.8	5.5	6.0	6.3	6.6	7.1	
ZSTNB20054-6-04			6				0.60			1.80	7.2	6.7	7.3	7.8	8.2	8.8	
ZSTNB20054-6.5-04			6.5				0.61			1.80	7.0	7.2	7.9	8.3	8.7	9.4	
ZSTNB20054-7-04			7				0.61			1.80	6.8	7.7	8.4	8.9	9.3	10.0	
ZSTNB2006-2-04	0.3	0.6	2	0.4	0.4	0.57	0.59	50	4	2.17	10.0	2.4	2.5	2.7	2.8	3.0	
ZSTNB2006-4-04			4				0.62			2.54	8.4	4.6	5.0	5.2	5.5	5.9	
ZSTNB2006-6-04			6				0.65			2.54	7.2	6.8	7.4	7.8	8.2	8.8	
ZSTNB2006-6-09			6	0.9			0.75			1.35	7.3	x	6.9	7.5	7.9	8.6	
ZSTNB2006-8-09			8	0.81			1.35			6.4	x	8.9	9.6	10.1	10.9		
ZSTNB2006-10-04			10	0.4			0.70			2.54	5.6	10.8	11.7	12.2	12.7	13.5	
ZSTNB2006-10-09			10	0.9			0.87			1.35	5.7	x	11.0	11.8	12.3	13.2	
ZSTNB2006-12-09			12	0.93			1.35			5.2	x	13.0	13.9	14.5	15.4		
ZSTNB2006-15-04			15	0.4			0.77			2.54	4.4	15.9	17.0	17.6	18.2	19.2	
ZSTNB2006-15-09			15	0.9			1.03			1.35	4.5	x	16.1	17.1	17.7	18.8	

X No application
- No interference

※ These tools are manufactured based on order received.

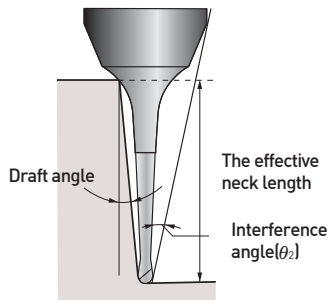

2 FLUTE, TAPER NECK BACK DRAFT TYPE

- If the workpiece has draft angle, the interference length will be longer than the L_2 .
- Please refer to the effective neck length for the various draft angles.
- In addition, the angle at which the tool will interfere with the workpiece is shown as the "interference angle θ_2 ", and should also be referred to.

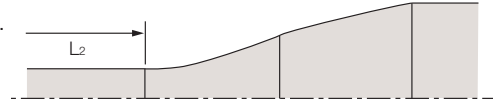

※The effective neck length shown is not an exact value and to avoid contact with the workpiece, we recommend the user control the precise value of this length.

EDP. No.	Dimension(mm)										Effective Neck Length					STOCK	
	R	D	L ₂	θ	L ₁	d ₁	d ₂	L ₃	d ₃	App. L	θ_2	0.5°	1°	1.5°	2°		3°
ZSTNB2008-4-04	0.4	0.8	4	0.4	0.5	0.77	0.82	50	4	2.64	8.3	4.6	4.9	5.2	5.5	5.9	
ZSTNB2008-6-04			6				0.85			2.64	7.1	6.6	7.1	7.5	7.7	8.3	
ZSTNB2008-8-09			8	0.9			1.01	1.45		6.3	x	8.9	9.6	10.1	10.9		
ZSTNB2008-12-09			12				1.13	1.45		5.0	x	13.0	13.9	14.5	15.4		
ZSTNB2008-16-09			16	1.26			1.45	4.2		x	17.1	18.1	18.8	19.9			
ZSTNB2009-4-04	0.45	0.9	4	0.4	0.6	0.86	0.91	50	4	3.46	8.2	4.5	4.7	4.9	5.1	5.4	
ZSTNB2009-8-04			8				0.96	55		3.46	6.1	8.7	9.3	9.7	10.0	10.6	
ZSTNB2009-12-04			12				1.02	3.46		4.8	12.9	13.8	14.4	14.9	15.7		
ZSTNB2009-16-04			16				1.08	3.46		4.0	17.0	18.0	18.7	19.3	20.5		
ZSTNB2009-18-04			18				1.10	3.46		3.7	19.1	20.1	20.9	21.5	23.1		
ZSTNB2009-20-04			20				1.13	3.46		3.4	21.1	22.2	23.0	23.6	25.6		
ZSTNB2009-22-04			22				1.16	3.46		3.2	23.1	24.3	25.1	25.8	28.2		
ZSTNB2009-24-04			24				1.19	3.46		3.0	25.2	26.4	27.2	27.9	-		
ZSTNB2010-6-04	0.5	1	6	0.4	0.8	0.94	1.01	50	6	5.09	8.3	6.8	7.2	7.5	7.8	8.3	
ZSTNB2010-8-04			8				1.04	5.09		7.5	8.8	9.3	9.7	10.0	10.6		
ZSTNB2010-10-04			10				1.07	55		5.09	6.8	11.0	11.7	12.3	12.7	13.5	
ZSTNB2010-10-09			10	0.9			1.23	2.70		6.9	x	11.2	11.9	12.4	13.2		
ZSTNB2010-15-09			15				1.39	2.70		5.7	x	16.2	17.1	17.8	18.8		
ZSTNB2010-20-04			20	0.4			1.21	5.09		4.7	21.2	22.3	23.0	23.6	25.7		
ZSTNB2010-20-09			20	0.9			1.54	2.70		4.8	x	21.3	22.4	23.1	24.6		
ZSTNB2010-25-09			25				1.70	2.70		4.2	x	26.4	27.6	28.4	30.8		
ZSTNB2010-30-04			30	0.4			1.35	5.09		3.6	31.3	32.7	33.6	34.8	38.5		
ZSTNB2010-30-09			30	0.9			1.86	2.70		3.7	x	31.4	32.8	33.7	36.9		
ZSTNB2010-35-09			35				2.02	2.70		3.3	x	36.5	38.0	39.0	43.1		
ZSTNB2010-40-09			40				2.17	2.70		3.0	x	41.6	43.2	44.4	-		
ZSTNB2010-50-09			50	2.49			2.70	2.5		x	51.7	53.5	55.5	-			
ZSTNB2010-60-09			60	2.80			2.70	2.2		x	61.8	63.8	66.6	-			
ZSTNB2010-70-09			70	3.11			2.70	1.9		x	71.9	74.0	-	-			
ZSTNB2015-8-04	0.75	1.5	8	0.4	1.35	1.42	1.51	55	6	7.07	7.3	8.9	9.4	9.7	10.0	10.6	
ZSTNB2015-10-04			10				1.54			7.07	6.6	10.9	11.5	11.9	12.2	12.9	

X No application
- No interference

※ These tools are manufactured based on order received.

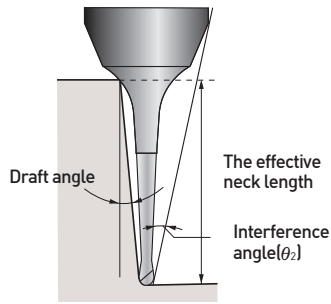

2 FLUTE, TAPER NECK BACK DRAFT TYPE

- If the workpiece has draft angle, the interference length will be longer than the L_2 .
- Please refer to the effective neck length for the various draft angles.
- In addition, the angle at which the tool will interfere with the workpiece is shown as the "interference angle θ_2 ", and should also be referred to.

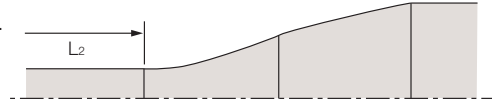

※The effective neck length shown is not an exact value and to avoid contact with the workpiece, we recommend the user control the precise value of this length.

EDP. No.	Dimension(mm)										Effective Neck Length					STOCK						
	R	D	L ₂	θ	L ₁	d ₁	d ₂	L ₃	d ₃	App. L	θ_2	0.5°	1°	1.5°	2°		3°					
ZSTNB2015-12-04	0.75	1.5	12	0.4	1.35	1.42	1.57	55	6	7.07	6.0	13.0	13.6	14.0	14.4	15.4						
ZSTNB2015-15-09			15	0.9			1.85	60		3.89	5.4	x	16.4	17.2	17.8	18.8						
ZSTNB2015-20-09			20				2.01	65		3.89	4.5	x	21.4	22.4	23.2	24.7						
ZSTNB2015-30-09			30				2.32	75		3.89	3.4	x	31.5	32.9	33.7	37.0						
ZSTNB2018-4-04	0.9	1.8	4	0.4	1.6	1.73	1.76	50	6	4.38	9.2	4.6	4.8	4.9	5.1	5.4						
ZSTNB2018-8-04			8				1.82			6.61	7.1	8.6	9.0	9.2	9.4	10.2						
ZSTNB2018-12-04			12				1.88			6.61	5.8	12.9	13.5	14.0	14.4	15.4						
ZSTNB2018-16-04			16				1.93	6.61		4.9	17.0	17.7	18.3	18.7	20.5							
ZSTNB2018-20-04			20				1.99	6.61		4.3	21.2	22.3	23.0	23.6	25.6							
ZSTNB2018-24-04			24				2.04	6.61		3.8	25.3	26.5	27.3	27.9	30.8							
ZSTNB2018-28-04			28				2.10	6.61		3.4	29.4	30.6	31.5	32.4	35.9							
ZSTNB2018-32-04			32				2.15	6.61		3.0	33.4	34.8	35.7	37.1	-							
ZSTNB2018-36-04			36				2.21	6.61		2.8	37.5	38.9	39.9	41.7	-							
ZSTNB2018-38-04			38				2.24	6.61		2.7	39.5	41.0	42.0	44.0	-							
ZSTNB2018-40-04			40				2.27	6.61		2.6	41.5	43.1	44.2	46.3	-							
ZSTNB2020-8-04			1				2	8		0.4	1.7	1.92	2.01	50	6	7.42	7.0	8.7	9.0	9.2	9.5	10.2
ZSTNB2020-12-04	12	2.06		55	7.42	5.7		13.0	13.6				14.0	14.4		15.4						
ZSTNB2020-16-04	16	2.12		60	7.42	4.8		17.0	17.7				18.3	18.7		20.5						
ZSTNB2020-20-04	20	2.18		65	7.42	4.1		21.3	22.3				23.0	23.6		25.6						
ZSTNB2020-20-09	20	2.50		65	4.24	4.2		x	21.4	22.4			23.2	24.6								
ZSTNB2020-25-09	25	2.65		65	4.24	3.6		x	26.5	27.7			28.5	30.8								
ZSTNB2020-30-04	30	2.32		70	7.42	3.1		31.4	32.7	33.6			34.8	38.5								
ZSTNB2020-30-09	30	2.81		70	4.24	3.2		x	31.6	32.9			33.7	36.9								
ZSTNB2020-35-09	35	2.97		75	4.24	2.8		x	36.6	38.0			39.0	-								
ZSTNB2020-40-04	40	2.46		80	7.42	2.5		41.5	43.1	44.2			46.3	-								
ZSTNB2020-40-09	40	3.12		80	4.24	2.6		x	41.7	43.2			44.5	-								
ZSTNB2020-50-09	50	3.44		90	4.24	2.1		x	51.8	53.5			55.5	-								
ZSTNB2020-60-09	60	3.75		100	4.24	1.8		x	61.9	63.8			-	-								
ZSTNB2020-70-09	70	4.07		110	4.24	1.6		x	72.0	74.1			-	-								
ZSTNB2030-8-04	1.5	3		8	0.4	2.5		2.86	2.94	50			6	8.50		6.3	8.8	9.1	9.3	9.5	10.3	
ZSTNB2030-16-04				16					3.05	55				12.52		4.1	17.2	17.8	18.3	18.7	20.6	

※ These tools are manufactured based on order received.

X No application
- No interference

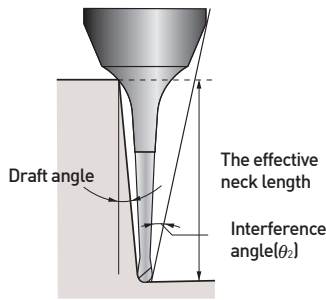

2 FLUTE, TAPER NECK BACK DRAFT TYPE

- If the workpiece has draft angle, the interference length will be longer than the L_2 .
- Please refer to the effective neck length for the various draft angles.
- In addition, the angle at which the tool will interfere with the workpiece is shown as the "interference angle θ_2 ", and should also be referred to.

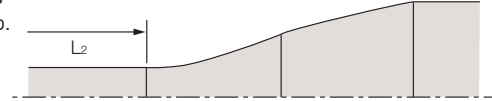

※The effective neck length shown is not an exact value and to avoid contact with the workpiece, we recommend the user control the precise value of this length.

EDP. No.	Dimension(mm)										Effective Neck Length					STOCK		
	R	D	L ₂	θ	L ₁	d ₁	d ₂	L ₃	d ₃	App. L	θ_2	0.5°	1°	1.5°	2°		3°	
ZSTNB2030-20-04	1.5	3	20	0.4	2.5	2.86	3.10	60	6	12.52	3.4	21.2	22.0	22.6	23.3	25.7		
ZSTNB2030-30-04			30				3.24			12.52	2.5	31.6	32.8	33.7	34.9	-		
ZSTNB2030-30-09			30				3.72	6.95		2.6	x	31.8	33.0	33.8	-			
ZSTNB2030-40-04			40	0.4			80	6.95		3.38	12.52	2.0	41.7	43.2	44.3	-	-	
ZSTNB2030-40-09			40	0.9						4.04	6.95	2.0	x	41.9	43.3	-	-	
ZSTNB2030-50-09			50				4.35			6.95	1.7	x	52.0	53.6	-	-		
ZSTNB2030-60-09			60				4.67			6.95	1.4	x	62.1	-	-	-		
ZSTNB2030-70-09			70	4.98			6.95			1.2	x	72.1	-	-	-			
ZSTNB2040-20-10			2	4			20			1	8	3.86	4.28	70	8	12.01	5.0	20.5
ZSTNB2040-30-10	30	4.63			80	12.01	3.51		22.0				31.6	32.5		33.2	34.16	
ZSTNB2040-40-10	40	4.98			90	12.01	2.7		22.0				42.0	43.4		44.3	-	
ZSTNB2040-50-10	50	5.33			100	12.01	2.2		22.0				52.0	53.6		54.7	-	
ZSTNB2040-60-10	60	5.68			110	12.01	1.9	22.0	62.0				63.8	-		-		
ZSTNB2050-30-10	2.5	5	30	1	10	4.86	5.56	80	8	14.01	2.8	25.5	31.7	32.6	33.2	-		
ZSTNB2050-40-10			40				5.91	90		14.01	2.1	25.5	41.7	42.8	43.5	-		
ZSTNB2050-60-10			60				6.61	110		14.01	1.5	25.5	62.1	-	-	-		
ZSTNB2060-30-10	3	6	30	1	12	5.86	6.49	80	8	16.01	1.9	29.0	31.8	32.6	-	-		
ZSTNB2060-40-10			40				6.84	90		16.01	1.5	29.0	41.8	-	-	-		
ZSTNB2060-50-10			50				7.19	100		16.01	1.2	29.0	51.8	-	-	-		
ZSTNB2060-60-10			60				7.54	110		16.01	1.9	29.0	62.2	63.9	-	-		
ZSTNB2060-70-10			70				7.89	120		16.01	1.7	29.0	72.2	74.1	-	-		
ZSTNB2060-80-10	80	8.23	130	16.01	1.5	29.0	82.2	-	-	-								
ZSTNB2080-50-10	4	8	50	1	14	7.86	9.12	110	10	18.01	1.2	32.0	51.9	-	-	-		
ZSTNB2080-60-10			60				9.47	120		18.01	1.0	32.0	-	-	-	-		
ZSTNB2080-70-10			70				9.82	130		18.01	0.9	32.0	-	-	-	-		
ZSTNB2080-80-10			80				10.16	140		18.01	1.5	32.0	82.3	-	-	-		
ZSTNB2100-60-10	5	10	60	1	18	9.86	11.33	130	12	22.01	1.1	39.0	62.1	-	-	-		
ZSTNB2100-75-10			75				11.85	140		22.01	0.9	39.0	-	-	-	-		

X No application
- No interference

※ These tools are manufactured based on order received.

■ Tolerance

Diameter	Tolerance	Shank Dia.
up to 6	±0.005	h6
over 6	±0.01	

※Items can be changed for quality improvement without notice.

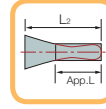
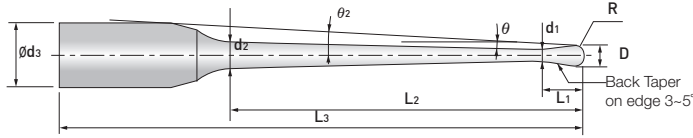

The effective neck length shown is not an exact value and to avoid contact with the workpiece, we recommend the user control the precise value of this length.

*R2 or higher is not applied to Back draft type.

ZSTNB30... series



EDP. No.	Dimension(mm)										Effective Neck Length					STOCK					
	R	D	L ₂	θ	L ₁	d ₁	d ₂	L ₃	d ₃	App. L	θ ₂	0.5°	1°	1.5°	2°		3°				
ZSTNB3020-8-04	1	2	8	0.4	1.7	1.92	2.01	50	6	7.42	7.0	8.7	9.0	9.2	9.5	10.2					
ZSTNB3020-12-04			12				2.06	55		7.42	5.7	13.0	13.6	14.0	14.4	15.4					
ZSTNB3020-16-04			16				2.12	60		7.42	4.8	17.0	17.7	18.3	18.7	20.5					
ZSTNB3020-20-04			20				2.18			7.42	4.1	21.3	22.3	23.0	23.6	25.6					
ZSTNB3020-20-09			20				0.9				2.50	65		4.24	4.2	x	21.4	22.4	23.2	24.6	
ZSTNB3020-25-09			25								2.65			4.24	3.6	x	26.5	27.7	28.5	30.8	
ZSTNB3020-30-04			30				0.4				2.32	70		7.42	3.1	31.4	32.7	33.6	34.8	38.5	
ZSTNB3020-30-09			30				0.9				2.81			4.24	3.2	x	31.6	32.9	33.7	36.9	
ZSTNB3020-35-09			35								2.97	75		4.24	2.8	x	36.6	38.0	39.0	-	
ZSTNB3020-40-04			40				0.4				2.46	80		7.42	2.5	41.5	43.1	44.2	46.3	-	
ZSTNB3020-40-09			40								3.12	80		4.24	2.6	x	41.7	43.2	44.5	-	
ZSTNB3020-50-09			50				0.9				3.44	90		4.24	2.1	x	51.8	53.5	55.5	-	
ZSTNB3020-60-09			60								3.75	100		4.24	1.8	x	61.9	63.8	-	-	
ZSTNB3020-70-09			70								4.07	110		4.24	1.6	x	72.0	74.1	-	-	
ZSTNB3030-8-04	1.5	3	8	0.4	2.5	2.86	2.94	50	6	8.50	6.3	8.8	9.1	9.3	9.5	10.3					
ZSTNB3030-16-04			16				3.05	55		12.52	4.1	17.2	17.8	18.3	18.7	20.6					
ZSTNB3030-20-04			20				3.10	60		12.52	3.4	21.2	22.0	22.6	23.3	25.7					
ZSTNB3030-30-04			30								3.24	70		12.52	2.5	31.6	32.8	33.7	34.9	-	
ZSTNB3030-30-09			30				0.9				3.72			6.95	2.6	x	31.8	33.0	33.8	-	
ZSTNB3030-40-04			40				0.4				3.38	80		12.52	2.0	41.7	43.2	44.3	-	-	
ZSTNB3030-40-09			40								4.04			6.95	2.0	x	41.9	43.3	-	-	
ZSTNB3030-50-09			50				0.9				4.35	90		6.95	1.7	x	52.0	53.6	-	-	
ZSTNB3030-60-09			60								4.67	100		6.95	1.4	x	62.1	-	-	-	
ZSTNB3030-70-09	70					4.98	110		6.95	1.2	x	72.1	-	-	-						
ZSTNB3040-20-10	2	4	20	1	8	3.86	4.28	70	8	12.01	5.0	20.5	21.6	22.3	22.8	23.5					
ZSTNB3040-30-10			30				4.63	80		12.01	3.6	22.0	31.6	32.5	33.2	34.1					
ZSTNB3040-40-10			40				4.98	90		12.01	2.7	22.0	42.0	43.4	44.3	-					
ZSTNB3040-50-10			50				5.33	100		12.01	2.2	22.0	52.0	53.6	54.7	-					
ZSTNB3040-60-10			60				5.68	110		12.01	1.9	22.0	62.0	63.8	-	-					
ZSTNB3050-30-10	2.5	5	30	1	10	4.86	5.56	80	8	14.01	2.8	25.5	31.7	32.6	33.2	-					
ZSTNB3050-40-10			40				5.91	90		14.01	2.1	25.5	41.7	42.8	43.5	-					
ZSTNB3050-60-10			60				6.61	110		12.52	1.5	25.5	62.1	-	-	-					

X No application
- No interference

* These tools are manufactured based on order received.

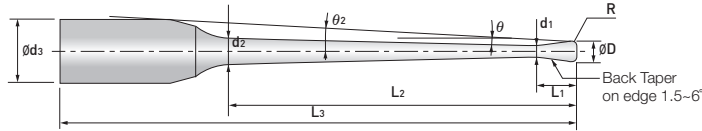

The effective neck length shown is not an exact value and to avoid contact with the workpiece, we recommend the user control the precise value of this length.

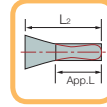

※ R2 or higher is not applied to Back draft type.

ZSTNR..... series



EDP. No.	Dimension(mm)										Effective Neck Length					STOCK							
	R	D	L ₂	θ	L ₁	d ₁	d ₂	L ₃	d ₃	App. L	θ ₂	0.5°	1°	1.5°	2°		3°						
ZSTNR2002-2-09005	0.2	0.05	2	0.9	0.15	0.17	0.23	50	4	1.10	10.0	x	2.8	3.1	3.4	3.9							
ZSTNR2004-4-09005	0.4	0.05	4	0.9	0.3	0.37	0.49	50	4	1.25	8.4	x	4.9	5.3	5.7	6.3							
ZSTNR2004-5-09005			5	0.9			0.52			1.25	7.8	x	5.9	6.4	6.8	7.5							
ZSTNR2004-4-0901		0.1	4	0.9			0.49			1.25	8.5	x	4.9	5.3	5.7	6.3							
ZSTNR2004-5-0901			5	0.9			0.52			1.25	7.9	x	5.9	6.4	6.8	7.5							
ZSTNR2005-5-0901	0.5	0.1	5	0.9	0.35	0.47	0.62	50	4	1.30	7.8	x	5.9	6.4	6.8	7.5							
ZSTNR2005-8-0901			8	0.9			0.71			1.30	6.4	x	9.0	9.7	10.2	11.0							
ZSTNR2005-10-0901			10	0.9			0.77			1.30	5.8	x	11.0	11.8	12.4	13.2							
ZSTNR2006-12-0901	0.6	0.1	12	0.9	0.4	0.57	0.93	55	4	1.35	5.1	x	13.0	13.9	14.5	15.5							
ZSTNR2006-15-0901			15	0.9			1.03			1.35	4.5	x	16.1	17.1	17.8	18.8							
ZSTNR2008-6-0402	0.8	0.2	6	0.4	0.5	0.77	0.85	50	4	2.64	7.0	6.6	7.1	7.5	7.8	8.3							
ZSTNR2008-12-0902			12	0.9			1.13			1.45	5.0	x	13.0	13.9	14.5	15.5							
ZSTNR2010-8-0402	1	0.2	8	0.4	0.8	0.94	1.04	55	6	5.09	7.4	8.8	9.3	9.7	10.1	10.6							
ZSTNR2010-10-0902			10	0.9			1.23			5.09	6.8	x	11.2	11.9	12.4	13.3							
ZSTNR2010-15-0902			15	0.9			1.39			2.70	5.6	x	16.3	17.2	17.8	18.8							
ZSTNR2010-20-0902			20	0.9			1.54			2.70	4.8	x	21.3	22.4	23.2	24.7							
ZSTNR2010-25-0902			25	0.9			1.70			2.70	4.1	x	26.4	27.6	28.5	30.9							
ZSTNR2010-30-0902			30	0.9			1.86			2.70	3.7	x	31.5	32.8	33.7	37.0							
ZSTNR2010-35-0902			35	0.9			2.02			2.70	3.3	x	36.5	38.0	39.0	43.2							
ZSTNR2010-8-0403		0.3	8	0.4	0.8	0.94	1.04	55	6	2.70	7.4	8.8	9.3	9.7	10.0	10.6							
ZSTNR2010-15-0903			15	0.9			1.39			2.70	5.6	x	16.3	17.2	17.8	18.8							
ZSTNR2010-25-0903			25	0.9			1.70			2.70	4.2	x	26.4	27.6	28.5	30.8							
ZSTNR2010-30-0903			30	0.9			1.86			2.70	3.7	x	31.5	32.8	33.7	37.0							
ZSTNR2015-10-0402			1.5	0.2			10			0.4	1.35	1.42	1.54	55	6	7.07	6.4	11.0	11.5	11.9	12.3	13.0	
ZSTNR2015-15-0902							15			0.9			1.85			7.07	5.3	x	16.4	17.3	17.9	18.9	
ZSTNR2015-20-0902							20			0.9			2.01			3.89	4.5	x	21.5	22.5	23.2	24.9	
ZSTNR2015-25-0902	25	0.9			2.16	3.89	3.9	x	26.6	27.7			28.5			31.0							
ZSTNR2015-30-0902	30	0.9			2.32	3.89	3.4	x	31.6	32.9			33.8			37.1							
ZSTNR2015-10-0403	0.3	10			0.4	1.54	55	3.89	6.4	11.0			11.5			11.9	12.3	13.0					

X No application
- No interference

※ These tools are manufactured based on order received.

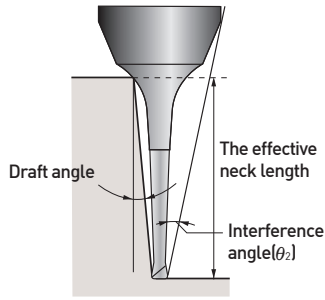

2 FLUTE, TAPER NECK BACK DRAFT TYPE

- If the workpiece has draft angle, the interference length will be longer than the L_2 .
- Please refer to the effective neck length for the various draft angles.
- In addition, the angle at which the tool will interfere with the workpiece is shown as the "interference angle θ_2 ", and should also be referred to.



※The effective neck length shown is not an exact value and to avoid contact with the workpiece, we recommend the user control the precise value of this length.

EDP. No.	Dimension(mm)										Effective Neck Length					STOCK						
	R	D	L_2	θ	L_1	d_1	d_2	L_3	d_3	App. L	θ_2	0.5°	1°	1.5°	2°		3°					
ZSTNR2015-20-0903	1.5	0.3	20	0.9	1.35	1.42	2.01	65	6	3.89	4.5	x	21.5	22.5	23.2	24.8						
ZSTNR2015-25-0903			25				2.16	70			3.9	x	26.5	27.7	28.5	31.0						
ZSTNR2015-30-0903			30				2.32	75			3.4	x	31.6	32.9	33.8	37.1						
ZSTNR2020-30-0902	2	0.2	30	0.9	1.7	1.92	2.81	70	6	7.42	3.1	x	31.6	32.9	33.8	37.2						
ZSTNR2020-40-0902			40				3.12	80			2.5	x	41.8	43.3	44.6	-						
ZSTNR2020-50-0902			50				3.44	90			2.1	x	51.9	53.6	55.7	-						
ZSTNR2020-12-0403			0.3				12	0.4			2.06	55	5.5	13.0	13.6	14.1	14.5	15.6				
ZSTNR2020-20-0903							20				2.50	65	4.1	x	21.5	22.5	23.2	24.9				
ZSTNR2020-30-0903							30				2.81	70	3.1	x	31.6	32.9	33.8	37.1				
ZSTNR2020-40-0903		40	3.12	80			2.5	x			41.7	43.3	44.6	-								
ZSTNR2020-50-0903		50	3.44	90			2.1	x			51.8	53.6	55.7	-								
ZSTNR2020-8-0405		0.5	0.4	8			0.9	2.01			50	6.8	8.7	9.0	9.3	9.5	10.4					
ZSTNR2020-12-0405				12				2.06			55	5.6	13.0	13.6	14.1	14.4	15.5					
ZSTNR2020-16-0405				16				2.12			60	4.7	17.0	17.8	18.3	18.7	20.7					
ZSTNR2020-20-0905			20	2.50			65	4.2			x	21.5	22.5	23.2	24.8							
ZSTNR2020-25-0905			25	2.65			65	3.6			x	26.6	27.7	28.5	30.9							
ZSTNR2020-30-0905			30	2.81			70	3.1			x	31.6	32.9	33.8	37.1							
ZSTNR2020-40-0905			40	3.12			80	2.5			x	41.7	43.2	44.6	-							
ZSTNR2020-50-0905			50	3.44			90	2.1			x	51.8	53.6	55.6	-							
ZSTNR2030-40-0902			3	0.2			40	0.9			2.5	2.86	4.04	80	6	6.95	2.0	x	42.0	43.4	-	-
ZSTNR2030-50-0902		50					4.35						90	1.6			x	52.1	53.7	-	-	
ZSTNR2030-60-0902	60	4.67			100	1.4	x		62.2	-			-	-								
ZSTNR2030-40-0903	0.3	40		4.04	80	2.0	x		42.0	43.4			-	-								
ZSTNR2030-50-0903		50		4.35	90	1.7	x		52.1	53.7			-	-								
ZSTNR2030-60-0903		60		4.67	100	1.4	x		62.2	-			-	-								
ZSTNR2030-40-0905	0.5	40		4.04	80	2.0	x		42.0	43.4			-	-								
ZSTNR2030-50-0905		50		4.35	90	1.7	x		52.1	53.7			-	-								
ZSTNR2030-60-0905		60		4.67	100	1.4	x		62.1	-			-	-								

X No application
- No interference

※ These tools are manufactured based on order received.

■ Tolerance

Mill Dia. (mm)	Shank Dia.
0 ~ -0.015	h5

※Items can be changed for quality improvement without notice.

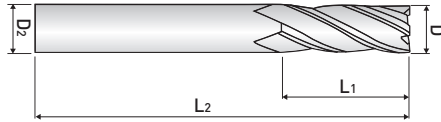

4 FLUTE, LONG CUT LENGTH BROKEN INDEX

- High precision and excellent surface due to each 4F unequal index geometry.
- Longer tool life over 50% as reducing chatter and resonance.

ZS124 ...series



EDP. No.	D	L ₁	L ₂	D ₂	STOCK
ZS124 020	2	5	45	4	•
ZS124 030	3	8	45	6	•
ZS124 040	4	10	45	6	•
ZS124 060	6	16	50	6	•
ZS124 080	8	20	60	8	•
ZS124 100	10	25	75	10	•
ZS124 120	12	35	85	12	•

■ Tolerance

Mill Dia, (mm)	Shank Dia,
0 ~ -0,02	h6

※ Items can be changed for quality improvement without notice.

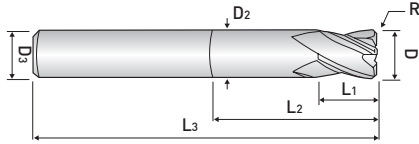

4 FLUTE, CORNER RADIUS BROKEN INDEX

- The impacting debut of new type endmill for high hardened steels up to HRC70 and high speed machining up to 200m/min.
- High precision and excellent surface due to each 4F unequal index geometry.
- Longer tool life over 50% as reducing chatter and resonance.

ZS1(2)04 ...series

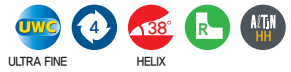

EDP. No.	D	R	L ₁	L ₂	L ₃	D ₂	D ₃	STOCK
ZS104010	1	-	1.5	4	45	0.9	4	•
ZS204010		0.05						•
ZS104020	2	-	3	6	45	1.9	4	•
ZS204020		0.05						•
ZS104030	3	-	4	7	45	2.9	6	•
ZS204030		0.1						•
ZS104040	4	-	5	9	45	3.8	6	•
ZS204040		0.1						•
ZS104060	6	-	7	14	50	5.8	6	•
ZS204060		0.2						•
ZS104080	8	-	9	18	60	7.8	8	•
ZS204080		0.2						•
ZS104100	10	-	12	25	75	9.7	10	•
ZS204100		0.2						•
ZS104120	12	-	15	30	75	11.7	12	•
ZS204120		0.3						•

■ Tolerance

Mill Dia. (mm)	Shank Dia.
0 ~ -0.02	h6

※Items can be changed for quality improvement without notice.

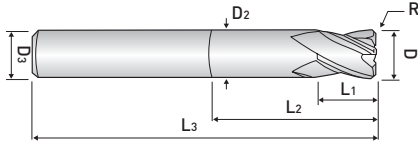

4 FLUTE, CORNER RADIUS BROKEN INDEX

- The impacting debut of new type endmill for high hardened steels up to HRc70 and high speed machining up to 200m/min.
- High precision and excellent surface due to each 4F unequal index geometry.
- Longer tool life over 50% as reducing chatter and resonance.

ZS204series

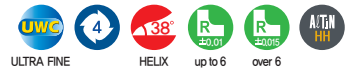

EDP. No.	D	R	L ₁	L ₂	L ₃	D ₂	D ₃	STOCK					
ZS20402000507	2	0.05	2.5	7	50	1.9	4	•					
ZS2040200107		0.1						•					
ZS2040300109	3	0.1	4	9	55	2.9	6	•					
ZS2040300209		0.2						•					
ZS2040300309		0.3		4				12	•				
ZS2040300312								16	•				
ZS2040300316								•					
ZS2040400212	4	0.2	5	12	55	3.8	6	•					
ZS2040400312		0.3		16				•					
ZS2040400316				20				•					
ZS2040400320				12				•					
ZS2040405012		0.5		5				16	•				
ZS2040400516								20	•				
ZS2040400520								12	•				
ZS2040401012								1	•				
ZS2040500116		5		0.1				6	16	60	4.8	6	•
ZS2040500216				0.2									•
ZS2040500316	0.3		•										
ZS2040500516	0.5		•										
ZS2040501016	1		•										
ZS2040600120	6	0.1	7	20	60	5.8	6	•					
ZS2040600220		0.2						•					
ZS2040600320		0.3						•					
ZS2040600520		0.5						•					
ZS2040601020		1						•					
ZS2040601520		1.5						•					

■ Tolerance

Mill Dia, (mm)	Shank Dia,
0 ~ -0,02	h6

※Items can be changed for quality improvement without notice.

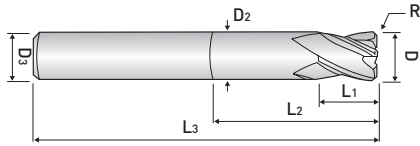

4 FLUTE, CORNER RADIUS BROKEN INDEX

- The impacting debut of new type endmill for high hardened steels up to HRC70 and high speed machining up to 200m/min.
- High precision and excellent surface due to each 4F unequal index geometry.
- Longer tool life over 50% as reducing chatter and resonance.

ZS204series



EDP. No.	D	R	L ₁	L ₂	L ₃	D ₂	D ₃	STOCK
ZS2040800125	8	0.1	9	25	60	8	7.8	•
ZS2040800225		0.2						•
ZS2040800325		0.3						•
ZS2040800525		0.5						•
ZS2040801025		1						•
ZS2040801525		1.5						•
ZS2040802025		2						•
ZS2041000232	10	0.2	11	32	75	10	9.7	•
ZS2041000332		0.3						•
ZS2041000532		0.5						•
ZS2041001032		1						•
ZS2041001532		1.5						•
ZS2041002032		2						•
ZS2041200238	12	0.2	12	38	75	12	11.7	•
ZS2041200338		0.3						•
ZS2041200538		0.5						•
ZS2041201038		1						•
ZS2041201538		1.5						•
ZS2041202038		2						•

■ Tolerance

Mill Dia. (mm)	Shank Dia.
0 ~ -0.02	h6

※Items can be changed for quality improvement without notice.

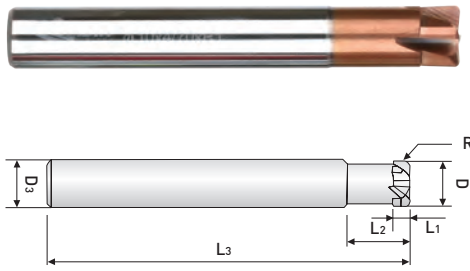

4 FLUTE, STUB CUT LENGTH, with EXTENDED NECK

- Designed to machine high hardened material by using newly developed raw-material and new coating.
- Applying straight flute design on the tool to minimize the corner radius breakage.
- Applying back draft type on the tool to maximize the reducing chatter and preventing deflection.

ZSPM4...-.. series

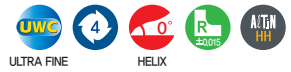

EDP. No.	D	R	L ₁	L ₂	L ₃	D ₃	STOCK
ZSPM4030-05	3	0.5	1.2	8	50	6	•
ZSPM4040-05	4	0.5	1.5	10	50	6	•
ZSPM4060-05	6	0.5	2.5	12	60	6	•
ZSPM4060-10		1					•
ZSPM4060-15		1.5					•
ZSPM4060-15L							90
ZSPM4080-10	8	1	3.5	16	60	8	•
ZSPM4080-20		2					•
ZSPM4080-20L							100
ZSPM4100-10	10	1	4	20	70	10	•
ZSPM4100-20		2					•
ZSPM4100-20L							100
ZSPM4120-20	12	2	5	25	80	12	•
ZSPM4120-30		3					•
ZSPM4120-30L							110

■ Tolerance

Mill Dia, (mm)	Shank Dia,
0 ~ -0,02	h6

※Items can be changed for quality improvement without notice.

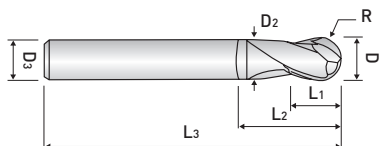

2 FLUTE, STUB CUT LENGTH, BALL NOSE with EXTENDED NECK

- Designed to machine high hardened materials up to HRC 70.
- Suitable for dry cutting & high speed cutting due to newly developed raw-material and new coating.
- Excellent workpiece finishes.

DB702 ...series



EDP. No.	D	R	L ₁	L ₂	L ₃	D ₂	D ₃	STOCK
DB702001	0.1	0.05	0.15	-	40	-	4	•
DB702002	0.2	0.1	0.3	-	40	-	4	•
DB702003	0.3	0.15	0.5	-	40	-	4	•
DB702004	0.4	0.2	0.6	-	40	-	4	•
DB702005	0.5	0.25	0.7	-	40	-	4	•
DB702006	0.6	0.3	0.9	-	40	-	4	•
DB702007	0.7	0.35	1.1	-	40	-	4	•
DB702008	0.8	0.4	1.2	-	40	-	4	•
DB702009	0.9	0.45	1.4	-	40	-	4	•
DB702010S4	1	0.5	1.5	-	45	-	4	•
DB702010				3	50	0.95	6	•
DB702015S4	1.5	0.75	2	-	45	-	4	•
DB702015				4	50	1.45	6	•
DB702020S4	2	1	2.5	-	45	-	4	•
DB702020				5	50	1.9	6	•
DB702025	2.5	1.25	3	7	50	2.45	6	•
DB702030S4	3	1.5	4	-	45	-	4	•
DB702030S				10	50	2.9	6	•
DB702030					60			•
DB702031					70			•
DB702040S4	4	2	5	-	45	-	4	•
DB702040S				10	50	3.7	6	•
DB702040					60			•
DB702041					70			•
DB702050	5	2.5	6	12	60	4.7	6	•
DB702060	6	3	7	12	60	5.6	6	•
DB702061					90	5.9		•
DB702080	8	4	9	15	70	7.4	8	•
DB702081					100	7.9		•
DB702100	10	5	11	25	75	9.4	10	•
DB702101					100	9.9		•
DB702120	12	6	12	25	80	11.4	12	•
DB702121					110	11.9		•

■ Tolerance

Radius (mm)		Shank Dia. h6
up to R3	±0.005	
over R3	±0.01	

※Items can be changed for quality improvement without notice.

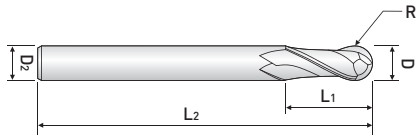

2 FLUTE, REGULAR LENGTH, BALL NOSE

- Designed to machine high hardened material up to HRc 70.
- Suitable for dry cutting & high speed cutting due to newly developed raw-material and new coating.
- Excellent workpiece finishes.

DB712 ...series



EDP. No.	Dia.	R	L ₁	L ₂	D ₂	STOCK
DB712010S	1	0.5	1.5	40	6	•
DB712010S4			2.5	50	4	•
DB712010					6	•
DB712012	1.2	0.6	3	50	6	•
DB712015S	1.5	0.75	2.5	40	6	•
DB712015S4			4	50	4	•
DB712015					6	•
DB712020S	2	1	3	40	6	•
DB712020S4			5	50	4	•
DB712020					6	•
DB712025	2.5	1.25	7	60	6	•
DB712030S	3	1.5	4.5	50	6	•
DB712030S4			8	60	4	•
DB712030					6	•
DB712040S	4	2	6	50	6	•
DB712040			8	70		•
DB712050S	5	2.5	7.5	50	6	•
DB712050			10	80		•
DB712060S	6	3	9	50	6	•
DB712060			12	90		•
DB712080S	8	4	12	50	8	•
DB712081			14	100		•
DB712100S	10	5	15	60	10	•
DB712100			18	100		•
DB712120S	12	6	18	60	12	•
DB712120			22	110		•

■ Tolerance

Radius (mm)		Shank Dia.
up to R3	±0,005	h6
over R3	±0,01	

※Items can be changed for quality improvement without notice.

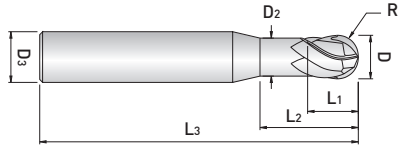

3FLUTE, BALL NOSE for finishing MOLD & DIE

- Designed to machine high hardened material up to HRC 70.
- Suitable for dry cutting & high speed cutting due to newly developed raw-material and new coating.
- Excellent workpiece finishes.

DB703 ...series



EDP. No.	D	R	L ₁	L ₂	L ₃	D ₂	D ₃	STOCK
DB703020	2	1	2.5	5	50	1.9	6	•
DB703025	2.5	1.25	3	7	50	2.4	6	•
DB703030S	3	1.5	4	10	50	2.9	6	•
DB703030					60			•
DB703031					70			•
DB703040S	4	2	5	10	50	3.7	6	•
DB703040					60			•
DB703041					70			•
DB703050	5	2.5	6	12	60	4.7	6	•
DB703060	6	3	7	12	60	5.6	6	•
DB703061					90	5.9		•
DB703080	8	4	9	15	70	7.4	8	•
DB703081					100	7.9		•
DB703100	10	5	11	25	75	9.4	10	•
DB703101					100	9.9		•
DB703120	12	6	12	25	80	11.4	12	•
DB703121					110	11.9		•

■ Tolerance

Radius (mm)		Shank Dia.
up to R3	±0,005	
over R3	±0,01	

※Items can be changed for quality improvement without notice.

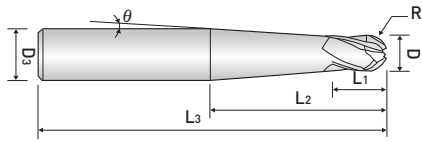

4FLUTE, TAPER NECK, FINISHING MOLD & DIE

- Designed to machine high hardened material up to HRc 70.
- Suitable for dry cutting & high speed cutting due to newly developed raw-material and new coating.
- Excellent workpiece finishes.

DB734 ...series



EDP. No.	D	R	L ₁	L ₂	L ₃	θ	D ₃	STOCK
DB734020-2.5	2	1	2	25	60	2.5	4	•
DB734020-3.5				18		3.5		•
DB734025-2.5	2.5	1.25	3	20	60	2.5	4	•
DB734025-3.0				17		3		•
DB734030-2.0	3	1.5	3	46	70	2	6	•
DB734030-2.5				37		2.5		•
DB734040-2.0	4	2.0	4	33	70	2	6	•
DB734040-2.5				27		2.5		•
DB734050-2.5	5	2.5	5	16	70	2.5	6	•
DB734060-1.5	6	3.0	6	44	100	1.5	8	•
DB734060-2.5				29		2.5		•
DB734080-1.5	8	4.0	8	46	100	1.5	10	•
DB734080-2.5				31		2.5		•
DB734100-1.5	10	5.0	10	48	110	1.5	12	•
DB734100-2.5				33		2.5		•

■ Tolerance

Radius (mm)	Shank Dia.
± 0,01	h6

※ Items can be changed for quality improvement without notice.

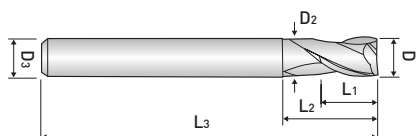

2 FLUTE, STUB CUT LENGTH, with EXTENDED NECK

- Designed to machine high hardened materials up to HRC 70.
- Suitable for dry cutting & high speed cutting due to newly developed raw-material and new coating.

ZE702 ...series



EDP. No.	D	L ₁	L ₂	L ₃	D ₂	D ₃	STOCK
ZE702001	0.1	0.2	-	40	-	4	•
ZE702002	0.2	0.4	-	40	-	4	•
ZE702003	0.3	0.5	-	40	-	4	•
ZE702004	0.4	0.7	-	40	-	4	•
ZE702005	0.5	1	-	40	-	4	•
ZE702006	0.6	1.2	-	40	-	4	•
ZE702007	0.7	1.4	-	40	-	4	•
ZE702008	0.8	1.6	-	40	-	4	•
ZE702009	0.9	2	-	40	-	4	•
ZE702010S4	1	1.5	-	40	-	4	•
ZE702010						6	•
ZE702015	1.5	2.2	-	40	-	6	•
ZE702020S4	2	3	6	40	1.9	4	•
ZE702020s						6	•
ZE702025	2.5	4	6	40	2.4	6	•
ZE702030	3	4	7	45	2.9	6	•
ZE702035	3.5	6	9	45	3.3	6	•
ZE702040	4	6	9	45	3.8	6	•
ZE702045	4.5	6	10	45	4.3	6	•
ZE702050	5	6	11	50	4.8	6	•
ZE702060	6	7	14	50	5.8	6	•
ZE702080	8	9	18	60	7.8	8	•
ZE702100	10	12	25	75	9.7	10	•
ZE702120	12	15	30	75	11.7	12	•
ZE702160	16	18	38	90	15.7	16	•
ZE702200	20	24	45	100	19.7	20	•

■ Tolerance

Mill Dia. (mm)		Shank Dia.
Diameter	Tolerance	
up to 6	0 ~ -0,012	h6
over 6	0 ~ -0,015	

*Items can be changed for quality improvement without notice.

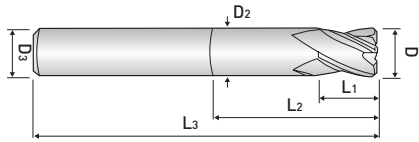

4 FLUTE, STUB CUT LENGTH, with EXTENDED NECK

- Designed to machine high hardened materials up to HRc 70.
- Suitable for dry cutting & high speed cutting due to newly developed raw-material and new coating.

ZE704 ...series



EDP. No.	D	L ₁	L ₂	L ₃	D ₂	D ₃	STOCK
ZE704010S4	1	1.5	-	40	-	4	•
ZE704010						6	•
ZE704015	1.5	2.2	-	40	-	6	•
ZE704020S4	2	3	6	40	1.9	4	•
ZE704020						6	•
ZE704025	2.5	4	6	40	2.4	6	•
ZE704030	3	4	7	45	2.9	6	•
ZE704035	3.5	5	9	45	3.3	6	•
ZE704040	4	5	9	45	3.8	6	•
ZE704045	4.5	6	10	45	4.3	6	•
ZE704050	5	6	11	50	4.8	6	•
ZE704060	6	7	14	50	5.8	6	•
ZE704080	8	9	18	60	7.8	8	•
ZE704100	10	12	25	75	9.7	10	•
ZE704120	12	15	30	75	11.7	12	•
ZE704160	16	18	38	90	15.7	16	•
ZE704200	20	24	45	100	19.7	20	•

■ Tolerance

Mill Dia, (mm)		Shank Dia,
Diameter	Tolerance	
up to 6	0 ~ -0,012	h6
over 6	0 ~ -0,015	

※Items can be changed for quality improvement without notice.

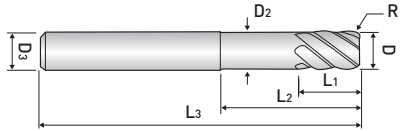

4 & 6 FLUTE, FINISHING for MOLD & DIE

- Designed to machine high hardened materials up to HRC 70.
- Suitable for dry cutting & high speed cutting due to newly developed raw-material and new coating.
- Corner radius (below 0.05) against chipping in high speed machining.

ZE724(6) ...series



EDP. No.	D	R	L ₁	L ₂	L ₃	D ₂	D ₃	Z	STOCK
ZE724010	1	-	1.5	5	45	0.95	6	4	•
ZE724015	1.5	-	2.2	6	45	1.45	6	4	•
ZE724020	2	0.05	3	8	45	1.9	6	4	•
ZE724030	3	0.05	4	9	50	2.9	6	4	•
ZE724040	4	0.05	5	12	50	3.8	6	4	•
ZE724050	5	0.05	6	15	50	4.8	6	4	•
ZE726060	6	0.05	7	20	60	5.8	6	6	•
ZE726080	8	0.05	9	25	70	7.8	8	6	•
ZE726100	10	0.05	12	32	75	9.7	10	6	•
ZE726120	12	0.05	15	38	80	11.7	12	6	•

■ Tolerance

Mill Dia. (mm)		Shank Dia.
Diameter	Tolerance	
up to 6	0 ~ -0,015	h6
over 6	0 ~ -0,02	

*Items can be changed for quality improvement without notice.

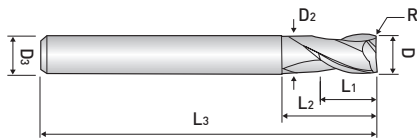

**2 FLUTE, STUB CUT LENGTH,
CORNER RADIUS with EXTENDED NECK**

- Applied various corner "Radius" and effected length.
- Suitable for dry cutting & high speed cutting due to newly developed raw-material and new coating.

ZR702series



EDP. No.	D	R	L ₁	L ₂	L ₃	D ₂	D ₃	STOCK	
ZR702 010 005 03 S4	1	0.05	1.5	3	50	0.95	4	•	
ZR702 010 005 04 S4				4				•	
ZR702 010 005 06 S4				6				•	
ZR702 010 005 08 S4				8				•	
ZR702 010 005 10 S4				10				•	
ZR702 010 01 03 S4		0.1		0.1				3	•
ZR702 010 01 04 S4								4	•
ZR702 010 01 06 S4								6	•
ZR702 010 01 08 S4								8	•
ZR702 010 01 10 S4								10	•
ZR702 010 02 03 S4		0.2		0.2				3	•
ZR702 010 02 04 S4								4	•
ZR702 010 02 06 S4								6	•
ZR702 010 02 08 S4								8	•
ZR702 010 02 10 S4								10	•
ZR702 010 03 03 S4		0.3		0.3				3	•
ZR702 010 03 04 S4								4	•
ZR702 010 03 06 S4								6	•
ZR702 010 03 08 S4								8	•
ZR702 010 03 10 S4								10	•
ZR702 010 01 04	1	0.1	1.5	4	50	0.95	6	•	
ZR702 010 01 06				6				•	
ZR702 010 02 04		0.2		4				•	
ZR702 010 02 06				6				•	
ZR702 010 02 10				10				•	
ZR702 010 02 12	12		•						
ZR702 012 02 08	1.2	0.2	2	8	50	1.15	6	•	
ZR702 012 02 12				12				•	
ZR702 015 005 04 S4	1.5	0.05	2.5	4	50	1.45	4	•	
ZR702 015 005 06 S4				6				•	
ZR702 015 005 08 S4				8				•	
ZR702 015 005 10 S4				10				•	
ZR702 015 005 12 S4				12				•	
ZR702 015 01 04 S4		0.1		0.1				4	•
ZR702 015 01 06 S4								6	•
ZR702 015 01 08 S4								8	•
ZR702 015 01 10 S4								10	•
ZR702 015 01 12 S4								12	•

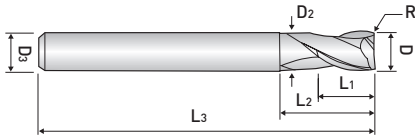

**2 FLUTE, STUB CUT LENGTH,
CORNER RADIUS with EXTENDED NECK**

- Applied various corner "Radius" and effected length.
- Suitable for dry cutting & high speed cutting due to newly developed raw-material and new coating.

ZR702series



EDP. No.	D	R	L ₁	L ₂	L ₃	D ₂	D ₃	STOCK						
ZR702 015 02 04 S4	1.5	0.2	2.5	4	50	1.45	4	•						
ZR702 015 02 06 S4				6				•						
ZR702 015 02 08 S4				8				•						
ZR702 015 02 10 S4				10				•						
ZR702 015 02 12 S4				12				•						
ZR702 015 03 04 S4				4				0.3	6	•				
ZR702 015 03 06 S4		8		•										
ZR702 015 03 08 S4		10		•										
ZR702 015 03 10 S4		12		•										
ZR702 015 03 12 S4		4		0.5					6	•				
ZR702 015 05 04 S4		8							•					
ZR702 015 05 06 S4		10						•						
ZR702 015 05 08 S4	12	•												
ZR702 015 05 10 S4	4	0.2	6		•									
ZR702 015 05 12 S4	8		•											
ZR702 015 02 04	1.5		0.2	2.5	10	50	1.45	6	•					
ZR702 015 02 06					15				•					
ZR702 015 02 08					6				0.1	8	50	1.9	4	•
ZR702 015 02 10					10					•				
ZR702 015 02 15		12			•									
ZR702 020 01 06 S4	16	•												
ZR702 020 01 08 S4	20	•												
ZR702 020 01 10 S4	6	0.2	8	50	1.9	4	•							
ZR702 020 01 12 S4	10		•											
ZR702 020 01 16 S4	12		•											
ZR702 020 01 20 S4	16		•											
ZR702 020 02 06 S4	20		0.3				6	50	1.9	4	•			
ZR702 020 02 08 S4	8						•							
ZR702 020 02 10 S4	10	•												
ZR702 020 02 12 S4	12	•												
ZR702 020 02 16 S4	16	•												
ZR702 020 02 20 S4	20	•												
ZR702 020 03 06 S4	6	0.1	8	50	1.9	4	•							
ZR702 020 03 08 S4	10		•											
ZR702 020 03 10 S4	12		•											
ZR702 020 03 12 S4	16		•											
ZR702 020 03 16 S4	20		•											
ZR702 020 03 20 S4	2		•											

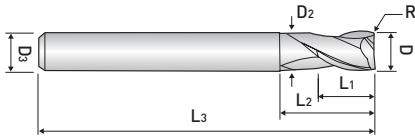

2 FLUTE, STUB CUT LENGTH, CORNER RADIUS with EXTENDED NECK

- Applied various corner "Radius" and effected length.
- Suitable for dry cutting & high speed cutting due to newly developed raw-material and new coating.

ZR702series

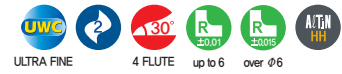

EDP. No.	D	R	L ₁	L ₂	L ₃	D ₂	D ₃	STOCK					
ZR702 020 05 06 S4	2	0.5	3	6	50	1.9	4	•					
ZR702 020 05 08 S4				8				•					
ZR702 020 05 10 S4				10				•					
ZR702 020 05 12 S4				12				•					
ZR702 020 05 16 S4				16				•					
ZR702 020 05 20 S4				20				•					
ZR702 020 01 08	2	0.1	3	8	50	1.9	6	•					
ZR702 020 01 12				12				•					
ZR702 020 02 06		0.2		6				•					
ZR702 020 02 09				9				•					
ZR702 020 02 16		0.3		16				•					
ZR702 020 03 06				6				•					
ZR702 020 05 06		0.5		6				•					
ZR702 020 05 09				9				•					
ZR702 020 05 12				12				•					
ZR702 020 05 16				16				•					
ZR702 025 02 08 S4		2.5		0.2				3.5	8	50	2.4	4	•
ZR702 025 02 10 S4									10				•
ZR702 025 02 12 S4	12		•										
ZR702 025 02 16 S4	16		•										
ZR702 025 03 08 S4	0.3		8	•									
ZR702 025 03 10 S4			10	•									
ZR702 025 03 12 S4			12	•									
ZR702 025 03 16 S4			16	•									
ZR702 025 05 08 S4	0.5		8	•									
ZR702 025 05 10 S4			10	•									
ZR702 025 05 12 S4			12	•									
ZR702 025 05 16 S4			16	•									
ZR702 030 01 08	3	0.1	*4.5	8	55	2.9	6	•					
ZR702 030 01 10				10				•					
ZR702 030 01 12				12				•					
ZR702 030 01 16				16				•					
ZR702 030 01 20				20				60	•				
ZR702 030 02 08				0.2				8	55	•			
ZR702 030 02 09	9	•											
ZR702 030 02 10	10	•											

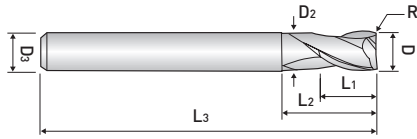

**2 FLUTE, STUB CUT LENGTH,
CORNER RADIUS with EXTENDED NECK**

- Applied various corner "Radius" and effected length.
- Suitable for dry cutting & high speed cutting due to newly developed raw-material and new coating.

ZR702series



EDP. No.	D	R	L ₁	L ₂	L ₃	D ₂	D ₃	STOCK						
ZR702 030 02 12	3	0.2	4.5	12	55	2.9	6	•						
ZR702 030 02 16				16				•						
ZR702 030 02 20				20				•						
ZR702 030 03 08	3	0.3	4.5	8	55	2.9	6	•						
ZR702 030 03 09				9				•						
ZR702 030 03 10				10				•						
ZR702 030 03 12				12				•						
ZR702 030 03 14				14				•						
ZR702 030 03 16				16				•						
ZR702 030 03 20				20				•						
ZR702 030 05 08				3				0.5	4.5	8	55	2.9	6	•
ZR702 030 05 09										9				•
ZR702 030 05 10										10				•
ZR702 030 05 12	12	•												
ZR702 030 05 16	16	•												
ZR702 030 05 20	20	•												
ZR702 030 10 08	3	1.0	4.5	8	55	2.9	6	•						
ZR702 030 10 10				10				•						
ZR702 030 10 12				12				•						
ZR702 030 10 16				16				•						
ZR702 030 10 20				20				•						
ZR702 030 10 25	25	•												
ZR702 040 01 10	4	1.0	6	10	55	3.8	6	•						
ZR702 040 01 12				12				•						
ZR702 040 01 16				16				•						
ZR702 040 01 20				20				•						
ZR702 040 01 25				25				•						
ZR702 040 02 10		4		0.2	6			10	55	3.8	6	•		
ZR702 040 02 12								12				•		
ZR702 040 02 16								16				•		
ZR702 040 02 20								20				•		
ZR702 040 02 25								25				•		
ZR702 040 03 10	4	0.3	6	10	55	3.8	6	•						
ZR702 040 03 12				12				•						
ZR702 040 03 16				16				•						
ZR702 040 03 20				20				•						
ZR702 040 03 25				25				•						

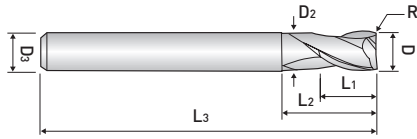

2 FLUTE, STUB CUT LENGTH, CORNER RADIUS with EXTENDED NECK

- Applied various corner "Radius" and effected length.
- Suitable for dry cutting & high speed cutting due to newly developed raw-material and new coating.

ZR702series



EDP. No.	D	R	L ₁	L ₂	L ₃	D ₂	D ₃	STOCK			
ZR702 040 05 10	4	0.5	6	10	55	3.8	6	•			
ZR702 040 05 12				12				•			
ZR702 040 05 16				16				•			
ZR702 040 05 20				20				•			
ZR702 040 05 25				25				•			
ZR702 040 05 30				30				•			
ZR702 040 10 10		1.0		1.0	10			70	60	6	•
ZR702 040 10 12					12						•
ZR702 040 10 16					16						•
ZR702 040 10 20					20						•
ZR702 040 10 25					25						•
ZR702 040 10 30					30						•
ZR702 050 03 18	5	0.3	8	18	60	4.8	6	•			
ZR702 060 02 20	6	0.2	9	20	60	5.8	6	•			
ZR702 060 03 20		0.3						•			
ZR702 060 05 20		0.5						•			
ZR702 060 10 20		1.0						•			
ZR702 060 15 20		1.5						•			
ZR702 060 20 20		2.0						•			
ZR702 080 02 25	8	0.2	12	25	60	7.8	8	•			
ZR702 080 03 25		0.3						•			
ZR702 080 05 25		0.5						•			
ZR702 080 10 25		1.0						•			
ZR702 080 15 25		1.5						•			
ZR702 100 02 32	10	0.2	15	32	70	9.7	10	•			
ZR702 100 03 32		0.3						•			
ZR702 100 05 32		0.5						•			
ZR702 100 10 32		1.0						•			
ZR702 100 15 32		1.5						•			
ZR702 100 20 32		2.0						•			
ZR702 120 03 38	12	0.3	18	38	80	11.7	12	•			
ZR702 120 05 38		0.5						•			
ZR702 120 10 38		1.0						•			
ZR702 120 15 38		1.5						•			
ZR702 120 20 38		2.0						•			

■ Tolerance

Mill Dia, (mm)		Shank Dia,
Diameter	Tolerance	
up to 6	0 ~ -0,012	h6
over 6	0 ~ -0,015	

※Items can be changed for quality improvement without notice.

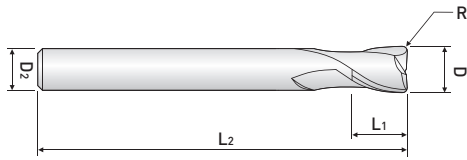

2 FLUTE, LONG SHANK, CORNER RADIUS

- Applied various corner "Radius" and effected length.
- Suitable for dry cutting & high speed cutting due to newly developed raw-material and new coating.

ZR732series



EDP. No.	Dia.	R	L ₁	L ₂	D ₂	STOCK
ZR732 010 01	1	0.1	2	50	6	•
ZR732 010 02		0.2				•
ZR732 010 03		0.3				•
ZR732 015 01	1.5	0.1	3	50	6	•
ZR732 015 02		0.2				•
ZR732 015 03		0.3				•
ZR732 015 05		0.5				•
ZR732 020 01	2	0.1	5	50	6	•
ZR732 020 02		0.2				•
ZR732 020 03		0.3				•
ZR732 020 05		0.5				•
ZR732 025 01	2.5	0.1	7	60	6	•
ZR732 025 02		0.2				•
ZR732 025 03		0.3				•
ZR732 025 05		0.5				•
ZR732 030 01	3	0.1	8	60	6	•
ZR732 030 02		0.2				•
ZR732 030 03		0.3				•
ZR732 030 05		0.5				•
ZR732 040 01	4	0.1	10	70	6	•
ZR732 040 02		0.2				•
ZR732 040 03		0.3				•
ZR732 040 05		0.5				•
ZR732 040 10		1.0				•

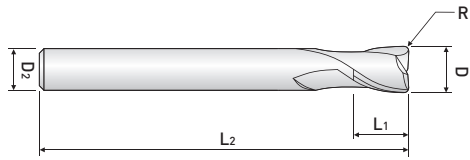

2 FLUTE, LONG SHANK, CORNER RADIUS

- Applied various corner "Radius" and effected length.
- Suitable for dry cutting & high speed cutting due to newly developed raw-material and new coating.

ZR732series



EDP. No.	Dia.	R	L ₁	L ₂	D ₂	STOCK
ZR732 050 01	5	0.1	13	80	6	•
ZR732 050 02		0.2				•
ZR732 050 03		0.3				•
ZR732 050 05		0.5				•
ZR732 050 10		1.0				•
ZR732 060 01	6	0.1	15	90	6	•
ZR732 060 02		0.2				•
ZR732 060 03		0.3				•
ZR732 060 05		0.5				•
ZR732 060 10		1.0				•
ZR732 080 01	8	0.1	20	100	8	•
ZR732 080 02		0.2				•
ZR732 080 03		0.3				•
ZR732 080 05		0.5				•
ZR732 080 10		1.0				•
ZR732 080 20		2.0				•
ZR732 100 02	10	0.2	25	100	10	•
ZR732 100 03		0.3				•
ZR732 100 05		0.5				•
ZR732 100 10		1.0				•
ZR732 100 20		2.0				•
ZR732 120 02	12	0.2	30	110	12	•
ZR732 120 03		0.3				•
ZR732 120 05		0.5				•
ZR732 120 10		1.0				•
ZR732 120 10		1.0				•
ZR732 120 20		2.0				•

■ Tolerance

Mill Dia. (mm)		Shank Dia.
Diameter	Tolerance	
up to 6	0 ~ -0,012	h6
over 6	0 ~ -0,015	

※Items can be changed for quality improvement without notice.

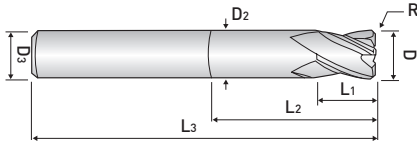

4 FLUTE, STUB CUT LENGTH, CORNER RADIUS with EXTENDED NECK

- Applied various corner "Radius" and effected length.
- Suitable for dry cutting & high speed cutting due to newly developed raw-material and new coating.

ZR704series

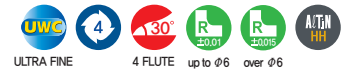

EDP. No.	D	R	L ₁	L ₂	L ₃	D ₂	D ₃	STOCK					
ZR704 010 01 03 S4	1	0.1	2	3	50	0.95	4	•					
ZR704 010 01 04 S4				4				•					
ZR704 010 01 06 S4				6				•					
ZR704 010 02 03 S4		0.2		3				•					
ZR704 010 02 04 S4				4				•					
ZR704 010 02 06 S4				6				•					
ZR704 010 03 03 S4		0.3		3				•					
ZR704 010 03 04 S4				4				•					
ZR704 010 03 06 S4				6				•					
ZR704 015 01 04 S4		1.5		0.1				2.5	4	50	1.45	4	•
ZR704 015 01 06 S4	6		•										
ZR704 015 02 04 S4	0.2		4	•									
ZR704 015 02 06 S4			6	•									
ZR704 015 03 04 S4	0.3		4	•									
ZR704 015 03 06 S4			6	•									
ZR704 020 01 06 S4	2	0.1	3	6	50	1.9	4	•					
ZR704 020 01 08 S4				8				•					
ZR704 020 02 06 S4		0.2		6				•					
ZR704 020 02 08 S4				8				•					
ZR704 020 03 06 S4		0.3		6				•					
ZR704 020 03 08 S4				8				•					
ZR704 020 05 06 S4		0.5		6				•					
ZR704 020 05 08 S4				8				•					
ZR704 020 02 08		2		0.2				3	8	50	1.9	6	•
ZR704 020 02 10									10				•
ZR704 020 02 12	12		•										
ZR704 025 01 06 S4	2.5	0.1	3.5	6	50	2.4	4	•					
ZR704 030 01 08	3	0.1	4	8	55	2.9	6	•					
ZR704 030 01 10				10				•					
ZR704 030 01 12				12				•					
ZR704 030 01 16				16				•					
ZR704 030 01 20				20				•					
ZR704 030 02 08				0.2				8	55	8	•		
ZR704 030 02 10		10			•								
ZR704 030 02 12		12			•								
ZR704 030 02 16		16			•								
ZR704 030 02 20		20		60	•								

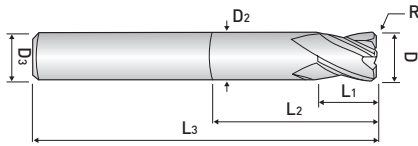

4 FLUTE, STUB CUT LENGTH, CORNER RADIUS with EXTENDED NECK

- Applied various corner "Radius" and effected length.
- Suitable for dry cutting & high speed cutting due to newly developed raw-material and new coating.

ZR704series



EDP. No.	D	R	L ₁	L ₂	L ₃	D ₂	D ₃	STOCK								
ZR704 030 03 08	3	0.3	4	8	55	2.9	6	•								
ZR704 030 03 09				9				•								
ZR704 030 03 10				10				•								
ZR704 030 03 12				12				•								
ZR704 030 03 16				16				•								
ZR704 030 03 20				20				60	•							
ZR704 030 05 08		0.5		8	4			8	55	2.9	6	•				
ZR704 030 05 09				9				9				•				
ZR704 030 05 10				10				10				•				
ZR704 030 05 12				12				12				•				
ZR704 030 05 16				16				16				•				
ZR704 030 05 20				20				60				•				
ZR704 030 10 08	1.0	8	4	8	55	2.9	6	•								
ZR704 030 10 10		10		10				•								
ZR704 030 10 12		12		12				•								
ZR704 030 10 16		16		16				•								
ZR704 030 10 20		20		60				•								
ZR704 040 01 10		4		0.1				6	10			55	3.8	6	•	
ZR704 040 01 12	12				12				•							
ZR704 040 01 16	16				16				•							
ZR704 040 01 20	20				60				•							
ZR704 040 01 25	25				60				•							
ZR704 040 02 10	0.2				10				6	10	55				3.8	6
ZR704 040 02 12				12	12					•						
ZR704 040 02 16			16	16	•											
ZR704 040 02 20			20	60	•											
ZR704 040 02 25			25	60	•											
ZR704 040 03 10			0.3	10	6	10	55			3.8		6				
ZR704 040 03 12	12			12		•										
ZR704 040 03 16	16			16		•										
ZR704 040 03 20	20			60		•										
ZR704 040 03 25	25			60		•										
ZR704 040 05 10	0.5			10		6			10		55					
ZR704 040 05 12			12	12	•											
ZR704 040 05 16			16	16	•											
ZR704 040 05 20			20	60	•											
ZR704 040 05 25			25	60	•											

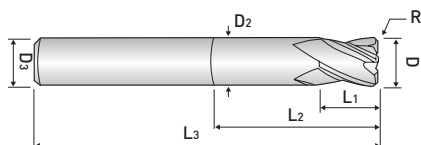

4 FLUTE, STUB CUT LENGTH, CORNER RADIUS with EXTENDED NECK

- Applied various corner "Radius" and effected length.
- Suitable for dry cutting & high speed cutting due to newly developed raw-material and new coating.

ZR704series



EDP. No.	D	R	L ₁	L ₂	L ₃	D ₂	D ₃	STOCK
ZR704 040 10 10	4	1.0	6	10	55	3.8	6	•
ZR704 040 10 12				12				•
ZR704 040 10 16				16				•
ZR704 040 10 20				20	•			
ZR704 040 10 25				25	60			•
ZR704 060 02 20	6	0.2	9	20	60	5.8	6	•
ZR704 060 03 20		0.3						•
ZR704 060 05 20		0.5						•
ZR704 060 10 20		1.0						•
ZR704 060 15 20		1.5						•
ZR704 060 20 20		2.0						•
ZR704 080 02 25	8	0.2	12	25	60	7.8	8	•
ZR704 080 03 25		0.3						•
ZR704 080 05 25		0.5						•
ZR704 080 10 25		1.0						•
ZR704 080 15 25		1.5						•
ZR704 080 20 25		2.0						•
ZR704 100 02 32	10	0.2	15	32	70	9.7	10	•
ZR704 100 03 32		0.3						•
ZR704 100 05 32		0.5						•
ZR704 100 10 32		1.0						•
ZR704 100 15 32		1.5						•
ZR704 100 20 32		2.0						•
ZR704 120 03 38	12	0.3	18	38	80	11.7	12	•
ZR704 120 05 38		0.5						•
ZR704 120 10 38		1.0						•
ZR704 120 15 38		1.5						•
ZR704 120 20 38		2.0						•

■ Tolerance

Mill Dia. (mm)		Shank Dia.
Diameter	Tolerance	
up to 6	0 ~ -0,012	h6
over 6	0 ~ -0,015	

※Items can be changed for quality improvement without notice.

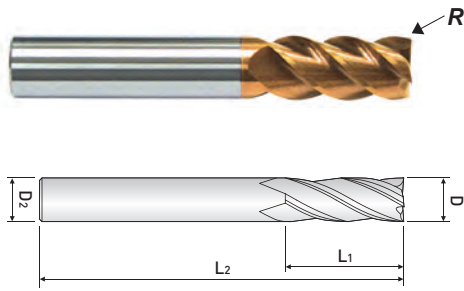

4FLUTE, 45° HELIX FINISHING MOLD & DIE

- Designed to machine high hardened material up to HRc 70.
- Suitable for dry cutting & high speed cutting due to newly developed raw-material and new coating.
- Possible to reduce machining cycle time by 2 x D finishing performance.

ZR714..... series



EDP. No.	Dia.	R	L ₁	L ₂	D ₂	STOCK
ZR7140303	3	0.3	8	50	6	•
ZR7140305		0.5				•
ZR7140403	4	0.3	11	50	6	•
ZR7140405		0.5				•
ZR7140410		1.0				•
ZR7140603	6	0.3	15	60	6	•
ZR7140605		0.5				•
ZR7140610		1.0				•
ZR7140803	8	0.3	20	60	8	•
ZR7140805		0.5				•
ZR7140810		1.0				•
ZR7140815		1.5				•
ZR7140820		2.0				•
ZR7141003	10	0.3	25	70	10	•
ZR7141005		0.5				•
ZR7141010		1.0				•
ZR7141015		1.5				•
ZR7141020		2.0				•
ZR7141025		2.5				•
ZR7141030	3.0	•				
ZR7141203	12	0.3	30	80	12	•
ZR7141205		0.5				•
ZR7141210		1.0				•
ZR7141215		1.5				•
ZR7141220		2.0				•
ZR7141225		2.5				•
ZR7141230	3.0	•				

■ Tolerance

Mill Dia. (mm)		Shank Dia.
Diameter	Tolerance	
up to 6	0 ~ -0,012	h6
over 6	0 ~ -0,015	

※Items can be changed for quality improvement without notice.

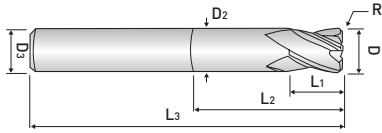

4 FLUTE, STUB CUT LENGTH, CORNER RADIUS with LONG SHANK

- Applied various corner "Radius" and effected length.
- Suitable for dry cutting & high speed cutting due to newly developed raw-material and new coating.

ZR724series



EDP. No.	D	R	L ₁	L ₂	L ₃	D ₂	D ₃	STOCK
ZR7240600520	6	0.5	9	20	90	5.8	6	•
ZR7240601020		1.0						•
ZR7240800525	8	0.5	12	25	100	7.7	8	•
ZR7240801025		1.0						•
ZR7241000532	10	0.5	15	32	100	9.7	10	•
ZR7241001032		1.0						•
ZR7241002032		2.0						•
ZR7241200538	12	0.5	18	38	110	11.7	12	•
ZR7241201038		1.0						•
ZR7241202038		2.0						•

■ Tolerance

Mill Dia. (mm)		Shank Dia.
Diameter	Tolerance	
up to 6	0 ~ -0,012	h6
over 6	0 ~ -0,015	

*Items can be changed for quality improvement without notice.

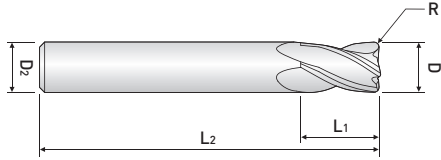

4 FLUTE, LONG SHANK, CORNER RADIUS

- Applied various corner "Radius" and effected length.
- Suitable for dry cutting & high speed cutting due to newly developed raw-material and new coating.

ZR734..... series

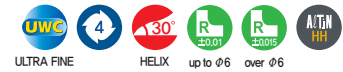

EDP. No.	Dia.	R	L ₁	L ₂	D ₂	STOCK
ZR734 010 01	1	0.1	2	50	6	•
ZR734 010 02		0.2				•
ZR734 010 03		0.3				•
ZR734 015 01	1.5	0.1	3	50	6	•
ZR734 015 02		0.2				•
ZR734 015 03		0.3				•
ZR734 015 05		0.5				•
ZR734 020 01	2	0.1	5	50	6	•
ZR734 020 02		0.2				•
ZR734 020 03		0.3				•
ZR734 020 05		0.5				•
ZR734 025 01	2.5	0.1	7	60	6	•
ZR734 025 02		0.2				•
ZR734 025 03		0.3				•
ZR734 025 05		0.5				•
ZR734 030 01	3	0.1	8	60	6	•
ZR734 030 02		0.2				•
ZR734 030 03		0.3				•
ZR734 030 05		0.5				•
ZR734 040 01	4	0.1	10	70	6	•
ZR734 040 02		0.2				•
ZR734 040 03		0.3				•
ZR734 040 05		0.5				•
ZR734 040 10		1.0				•

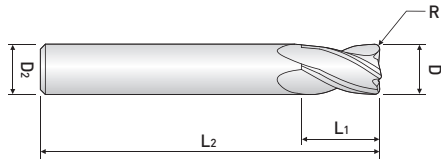

4 FLUTE, LONG SHANK, CORNER RADIUS

- Applied various corner "Radius" and effected length.
- Suitable for dry cutting & high speed cutting due to newly developed raw-material and new coating.

ZR734..... series

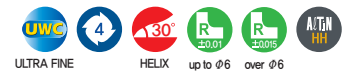

EDP. No.	Dia.	R	L ₁	L ₂	D ₂	STOCK
ZR734 050 01	5	0.1	13	80	6	•
ZR734 050 02		0.2				•
ZR734 050 03		0.3				•
ZR734 050 05		0.5				•
ZR734 050 10		1.0				•
ZR734 060 01	6	0.1	15	90	6	•
ZR734 060 02		0.2				•
ZR734 060 03		0.3				•
ZR734 060 05		0.5				•
ZR734 060 10		1.0				•
ZR734 080 01	8	0.1	20	100	8	•
ZR734 080 02		0.2				•
ZR734 080 03		0.3				•
ZR734 080 05		0.5				•
ZR734 080 10		1.0				•
ZR734 080 20		2.0				•
ZR734 100 02	10	0.2	25	100	10	•
ZR734 100 03		0.3				•
ZR734 100 05		0.5				•
ZR734 100 10		1.0				•
ZR734 100 20		2.0				•
ZR734 120 02	12	0.2	30	110	12	•
ZR734 120 03		0.3				•
ZR734 120 05		0.5				•
ZR734 120 10		1.0				•
ZR734 120 20		2.0				•

■ Tolerance

Mill Dia. (mm)		Shank Dia.
Diameter	Tolerance	
up to 6	0 ~ -0,012	h6
over 6	0 ~ -0,015	

※ Items can be changed for quality improvement without notice.

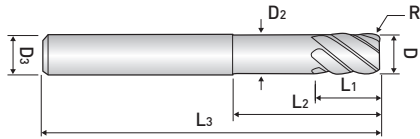

6 FLUTE, 45° HELIX STUB CUT LENGTH, CORNER RADIUS with EXTENDED NECK

- Applied various corner "Radius" and effected length.
- Suitable for dry cutting & high speed cutting due to newly developed raw-material and new coating.

ZR706series



EDP. No.	D	R	L ₁	L ₂	L ₃	D ₂	D ₃	STOCK
ZR7060600314	6	0.3	12	14	50	5.8	6	•
ZR7060600514		0.5						•
ZR7060800524	8	0.5	8	24	60	7.8	8	•
ZR7060801024		1.0						•
ZR7061000530	10	0.5	10	30	70	9.8	10	•
ZR7061001030		1.0						•
ZR7061200530	12	0.5	12	30	75	11.8	12	•
ZR7061201030		1.0						•

■ Tolerance

Mill Dia, (mm)	Shank Dia,
0 ~ -0,02	h6

※Items can be changed for quality improvement without notice.

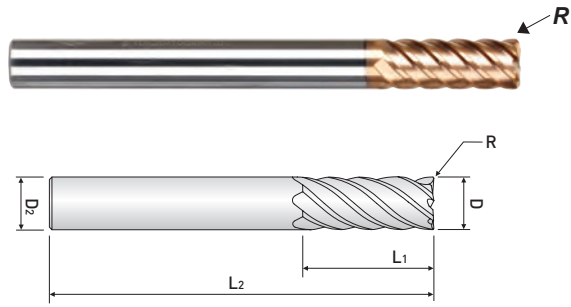

6 FLUTE, 45° HELIX, LONG SHANK, CORNER RADIUS

- Applied various corner "Radius" and effected length.
- Suitable for dry cutting & high speed cutting due to newly developed raw-material and new coating.

ZR736 ...series



EDP. No.	Dia.	R	L ₁	L ₂	D ₂	STOCK
ZR736 060 05	6	0.5	15	90	6	•
ZR736 060 10		1.0				•
ZR736 080 05	8	0.5	20	100	8	•
ZR736 080 10		1.0				•
ZR736 100 05	10	0.5	25	100	10	•
ZR736 100 10		1.0				•
ZR736 120 05	12	0.5	30	110	12	•
ZR736 120 10		1.0				•

■ Tolerance

Mill Dia. (mm)	Shank Dia.
0 ~ -0,02	h6

※Items can be changed for quality improvement without notice.

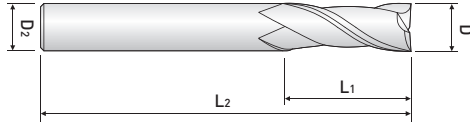

2 FLUTE, 35° HELIX REGULAR LENGTH

- Designed to machine high hardened materials up to HRC 70.
- Suitable for dry cutting & high speed cutting due to newly developed raw-material and new coating.

ZE712 ...series



EDP. No.	Dia.	L ₁	L ₂	D ₂	STOCK
ZE712010-02	1.0	2	40	6	•
ZE712010		3			•
ZE712010-04		4			•
ZE712012	1.2	3	40	6	•
ZE712015	1.5	4	40	6	•
ZE712015-06		6			•
ZE712015-08		8			•
ZE712020	2.0	5	40	6	•
ZE712020-08		8			•
ZE712020-10		10			•
ZE712025	2.5	6	40	6	•
ZE712030	3.0	8	45	6	•
ZE712030-10		10	50		•
ZE712030-12		12			•
ZE712035	3.5	10	45	6	•
ZE712040	4.0	10	45	6	•
ZE712040-12		12	50		•
ZE712040-16		16	60		•
ZE712045	4.5	11	45	6	•
ZE712050	5.0	13	50	6	•
ZE712055	5.5	13	50	6	•
ZE712060	6.0	13	50	6	•
ZE712060-15		15	60		•
ZE712065	6.5	16	60	8	•
ZE712070	7.0	18	60	8	•
ZE712080	8.0	19	60	8	•
ZE712100	10.0	22	70	10	•
ZE712100-25		25			•
ZE712120	12.0	26	75	12	•
ZE712120-30		30	80		•

■ Tolerance

Mill Dia. (mm)	Shank Dia.
0 ~ -0,02	h6

※ Items can be changed for quality improvement without notice.

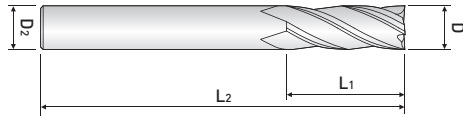

4 FLUTE, 45° HELIX REGULAR LENGTH

- Designed to machine high hardened materials up to HRc 70.
- Suitable for dry cutting & high speed cutting due to newly developed raw-material and new coating.

ZE714 ...series



EDP. No.	Dia.	L ₁	L ₂	D ₂	STOCK
ZE714 010	1.0	2.5	40	6	•
ZE714 012	1.2	3	40	6	•
ZE714 015	1.5	4	40	6	•
ZE714020	2.0	5	40	6	•
ZE714025	2.5	6	40	6	•
ZE714030	3.0	8	45	6	•
ZE714 035	3.5	9	45	6	•
ZE714040	4.0	10	45	6	•
ZE714050	5.0	13	50	6	•
ZE714060	6.0	13	50	6	•
ZE714 060-15		15	60		•
ZE714080	8.0	19	60	8	•
ZE714100	10.0	22	70	10	•
ZE714 100-25		25			•
ZE714120	12.0	26	75	12	•
ZE714 120-30		30	80		•

■ Tolerance

Mill Dia. (mm)	Shank Dia.
0 ~ -0.02	h6

※Items can be changed for quality improvement without notice.

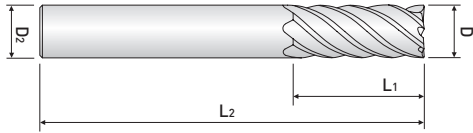

6 FLUTE, 50° HELIX REGULAR LENGTH

- Designed to machine high hardened materials up to HRc 70.
- Suitable for dry cutting & high speed cutting due to newly developed raw-material and new coating.

ZE716 ...series



EDP. No.	Dia.	L ₁	L ₂	D ₂	STOCK
ZE716060	6	13	50	6	•
ZE716080	8	18	60	8	•
ZE716100	10	22	70	10	•
ZE716120	12	26	75	12	•
ZE716160	16	35	90	16	•
ZE716200	20	44	100	20	•

■ Tolerance

Mill Dia, (mm)	Shank Dia,
0 ~ -0,02	h6

※Items can be changed for quality improvement without notice.